

Sheet metal plate design: a structured approach to product optimization in the presence of technological constraints

Original

Sheet metal plate design: a structured approach to product optimization in the presence of technological constraints / Fusano, L., Priarone, P.C., Avalle, M., DE FILIPPI, A.M.. - In: INTERNATIONAL JOURNAL, ADVANCED MANUFACTURING TECHNOLOGY. - ISSN 0268-3768. - STAMPA. - 56:(2011), pp. 31-45. [10.1007/s00170-011-3174-0]

Availability:

This version is available at: 11583/2432375 since:

Publisher:

Springer London

Published

DOI:10.1007/s00170-011-3174-0

Terms of use:

This article is made available under terms and conditions as specified in the corresponding bibliographic description in the repository

Publisher copyright

(Article begins on next page)

Sheet metal plate design: a structured approach to product optimization in the presence of technological constraints

Lorenzo Fusano · Paolo Claudio Priarone ·
Massimiliano Avalle · Augusto Mario De Filippi

Abstract Geometrical optimization of structural components is a topic of high interest for engineers involved with design activities mainly related to mass reduction. The study described in these pages focuses on the optimization of plates subjected to bending for which stiffness is obtained by a pattern of ribs. Although stiffening by means of ribs is a well-known and old technique, the design of ribs for maximum stiffness is often based on practice and experience. Classical optimization methods such as topological, topographical and parametric optimization fail to give an efficient design with a reasonable programming effort, especially when dealing with many and complex constraints. These constraints are both technical and technological. A most promising technique to obtain optimal rib patterns was to define a set of feasible rib trajectories and then to select the subset with the most efficient combinations. The result is not unique and a method to select the optimal patterns is required. In fact, the stiffening effect increases with increasing rib length, but at

a greater cost. A trade-off must be found between structural performance and cost: The tools to guide this selection process is the main objective of the paper, with particular attention in evaluating the stiffening due to the presence of beads on the plate with a close link with the production system and possible technological constraints which can occur during manufacturing processes, such as minimum rib distance or the presence of discontinuities or the presence of holes or other elements on the plate. A special tool with enforced rib cross section is considered, and optimal rib deployment has to be found. Numerical examples attached show the methodology and obtainable results.

Keywords Plate optimization · Rib pattern · Sheet metal working

1 Introduction

Most metal components in various industrial applications, including casing and containers, are made of formed thin sheet. Reduced thickness is mandatory for lightweight and reduced cost but, as it is obvious, both strength and stiffness suffer from this. The problem is especially serious when dealing with large size plates with a high ratio of size to thickness and of regular shape (that is, the two planar dimensions are comparable). To increase the lateral stiffness of a planar metal sheet, there are a few well-known methods, both aiming at pulling out some of the material from the mid-plane of the sheet. In thin metal sheets, this can be obtained by deforming it by folding, stretching, stamping, etc. The use of ribs is another classical technique

L. Fusano (✉)
University Centre of Alessandria, Politecnico di Torino,
viale Teresa Michel 5,
15121 Alessandria, Italy
e-mail: lorenzo.fusano@polito.it

P. C. Priarone · A. M. De Filippi
Department of Production Systems and Business Economics,
Politecnico di Torino,
corso Duca degli Abruzzi 24,
10129 Turin, Italy

M. Avalle
Department of Mechanics, Politecnico di Torino,
corso Duca degli Abruzzi 24,
10129 Turin, Italy

to increase, even significantly, the stiffness of a plate. The parameters that determine stiffening are, other than rib geometry (in terms of width, length, depth and section), their deployment on the component, that is, the layout over the planar surface. The choice of the optimal rib layout, according to the boundary conditions (in terms of loads and constraints applied) and to the required stiffness, is a problem subjected to many technological restrictions. It depends from the technology available to deform the material, and this has dramatic consequences on the manufacturing costs. For example, with some technology, it is possible to have ribs freely placed anywhere and even intersecting each other (with higher stiffness) whereas in other cases this is not possible, and it is also necessary to keep each single bead separated from the other by a minimum distance. Although the use of ribs and beads in plates is very old, their placement on the plate itself is usually done based on past experience or with some rule of thumb, typically without optimality criteria and, therefore, even with little effectiveness.

Recently, some authors have made attempts to propose mathematical tools to improve the design of rib or bead layout [1, 2], mainly using topological optimization methods [3, 4]. These works are, however, mainly theoretical and quite complex, not taking into account technological constraints and not providing a general methodological approach for the solution of this kind of problems.

The approach applied in the present work tries to provide a general methodology suitable for this kind of problems and the tools to define and select optimal solutions. In particular, the optimal or quasi-optimal layouts come from a selection among a number of possible layouts obtained from combinations of simple rib patterns. The selection of the initial set is a first problem: Among the theoretically infinite possibilities, a number must be discarded due to technological and practical constraints. The performance of these rib patterns is evaluated, and a subset containing the best

combinations is obtained. Of extreme importance is to stress the fact that a unique optimal layout does not exist, in general, without imposing additional conditions on stiffness or cost. As a rule, in fact, increasing the overall rib length results in increased stiffness, but at a higher manufacturing cost. Moreover, for the same overall rib length, there can be several solutions with different performance. Selection of optimal layouts must be made by defining selection charts and selection rules that will be described. After the description of the methodology, the results of a simple case (rectangular flat plate supported on the edges and loaded in the middle) together with an industrial case study of a real plate with all the technical constraints (holes, to put screws in well defined positions, obstructions due to components to be mounted, etc. as well as inadmissible intersections between ribs) are presented.

2 State of the art

Many authors have studied the topic of stiffening a sheet metal plate with different methodologies. However, they usually limit the discussion to a single geometry and a single loading case.

Díaz et al. [5] used an anisotropic material model to simulate the stiffening due to the presence of a rib. The objective of the optimization was to minimize the compliance of the plate by varying dimensions and orientation of beads. This was made by expressing shear and transverse stiffness of the plate in terms of only four variables that fully describe the anisotropy of the plate, and then the optimization problem is solved.

Yang et al. [1] proposed to include beam elements in a shell mesh and to perform topology optimization only on beams. The result is the optimum arrangement of beads represented by beam elements. Also the authors showed that efficiency of ribs decreases with the increasing of their overall length. This methodology is feasible in any structure

Fig. 1 Rib sizes (measures in millimetres, *above*) and ribbing process (*below*)

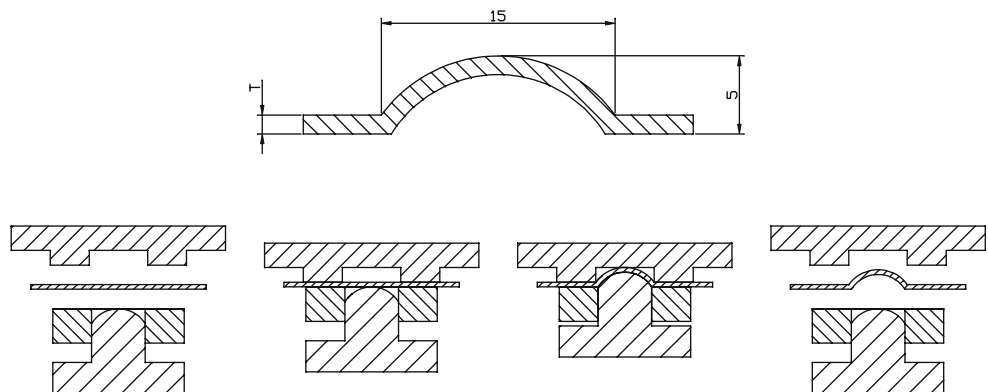

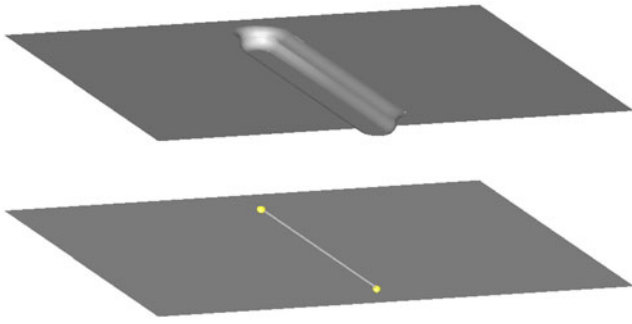

Fig. 2 An example of the original plate with the real bead (*above*) and the equivalent structure consisting of a flat plate assembled with a beam of correct properties (*below*) to provide equal stiffness as the original

but requires a coarse mesh to avoid excessively long computation time.

Chung and Lee [3] suggest to apply a reinforcement structure above the existing one and to perform topology optimization only on the reinforcement; also it is included a penalty function in topology algorithm to prohibit the intermediate densities (which give indefinite solutions).

Luo and Gea [4] used an orthotropic material model equivalent to a section reinforced by a bead; the optimization is performed on the orientation of the material in every shell. The result is the optimal direction of the bead in every element. The method is strongly mesh dependent because the number of the variables is equal to the elements.

Lam and Santhikumar [6] proposed an automatic method for bead deployment. It provides an initial step where the thickness of the plate changes to realize a variable thickness plate. Reinforcement ribs starts where thickness is greater and then is deployed on the plate with subsequent iterations. Park et al. [7] shows a method for increasing natural frequencies based on similar principles: Following a modal analysis of the part, beads are located starting from the elements with a higher strain modal energy and then expands to the surrounding elements. The

optimal layout is obtained again with subsequent iterations. Finally, Zhou et al. [2] introduced integrated algorithms of topological, sizing and shape optimization, thus making possible to carry out different optimizations at the same time.

Many of the existing finite element method (FEM) solvers include optimization tools; some of them, like LS-DYNA Genesis, Altair OptiStruct and FE Design Tosca, include methodologies specialized in bead deployment. The process is iterative and it calculates the optimal rib layout once defined some geometrical parameters (maximum height, draw angle and maximum and minimum width).

To date, a wide range of case studies has been covered, but there is still a lack of technological considerations about the nature of the ribs. In almost every existing method, the optimization gives a result in term of shape and position of the ribs, though neglecting that when dealing with processes like sheet metal punching, the shape of the bead is given by the tool: His dimensions and shape limit the freedom in building beads and ribs in the metal sheet (for example, in the minimum distance between two adjacent ribs, or to the minimum curvature of the rib when changing trajectory in the plane).

3 Optimization procedure

Automatic optimization methods are very efficient when the design space has the least possible number of constraints. Moreover, when dealing with complex real problems, it is also difficult to define constraints: It could happen that some technological constraints could not be properly modelled by actual solvers, for example, the minimum distance within two beads. Tools that make beads include a device for grabbing the plate that needs to work on a flat area, so it is necessary to keep a minimum distance between two ribs according to the tool which is in use. For

Fig. 3 Comparison between plate displacements in mm under central point load with approximated (*left*) and real (*right*) beads

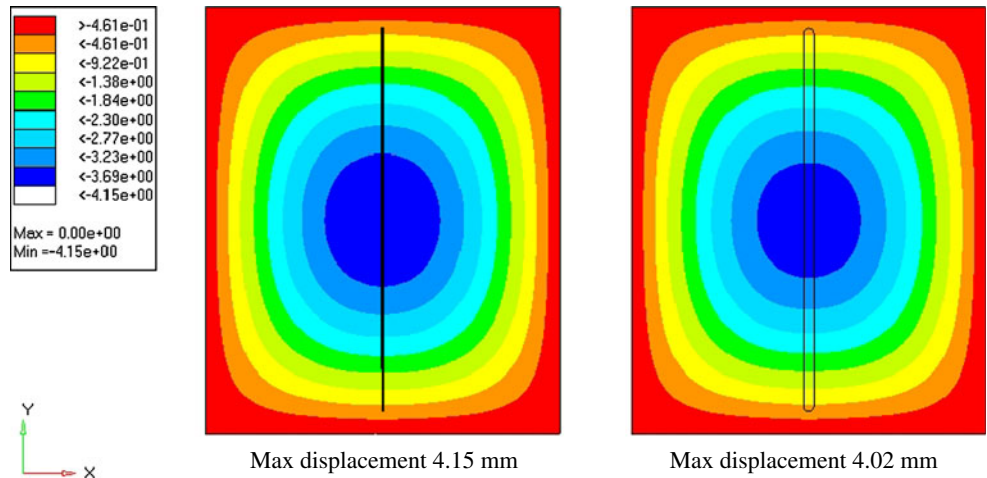

Table 1 Plate sizes depending on aspect ratios (constant area)

AR	Plate sizes	
	Width, b (mm)	Height, h (mm)
1	547.7	547.7
1.2	500.0	600.0
1.5	447.2	670.8
2	387.3	774.6

the same reason, the trajectory of a rib cannot intersect another one. Another important topic is related to bead shape: Existing optimization methods allow to generate rib patterns with minor possibility to constrain its shape. It is possible, for example, to align ribs in one or more directions and give symmetries or repetition patterns. It is also possible to define maximum height and minimum width and draw-angle of the rib, but it is not possible to enforce a shape to it. In modern metal plate manufacturing, ribs can be made with special tools by punching the plate along a path. Rib section is constrained by the shape of the tool itself, but its deployment on the metal sheet can be chosen almost freely.

It is necessary to develop a methodology to optimize rib deployment on a plate taking into account such limitations. However, optimization methods implemented in commercial codes hardly converge in these cases or could not be used at all.

An alternative possible solution consists in identifying a series of feasible layouts obtained through a combination of a number of simple rib trajectories: Linear paths along predefined directions, radial paths, elliptical or oval paths, etc. The optimization procedure will be a selection among the feasible combinations. It is possible to define in advance the feasible layouts so that the technological constraints are respected. In some cases, this is not possible a priori and adjustments have to be made by small modifications of the chosen optimal layout.

Lev.	T	L	C	R
0				
1				-
2				
3				-

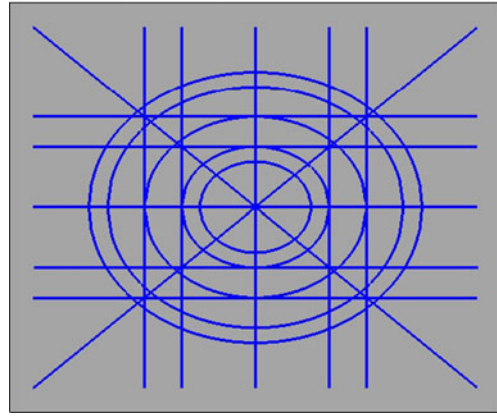
Fig. 4 Layouts and variation levels**Fig. 5** Plate FE model with all the ribs

Since the tools making the ribs work at a nearly constant speed during manufacturing operations, it can be assumed that the overall rib length is directly proportional to the manufacturing time and, therefore, to the cost. The objective of the optimization is then to achieve the maximum stiffness or at least the required stiffness using the least possible total rib length. For this, a procedure has been developed that works by switching on or off each individual rib, searching the combination able to give the optimum result.

The plate model is parameterized by using variables that turn on or off each individual rib (with a technique that will be explained later): A material is assigned to each single rib, whose elastic modulus can be changed between the real material value and a virtually null value (that is a very small value negligible if compared to the real value: For computational reasons, it is not possible to use an elastic modulus value equal to zero). When calculating combinations, variables can assume only extreme values of the range (discrete variables), so that every single rib can be set on and off independently by others.

In order to execute all the required simulations, a run manager software was used, the DOE module of the Altair HyperStudy 10.0 program. The FE model was used in a full-factorial design where each individual rib is one factor. The two levels associated with each factor correspond to a single rib pattern activated or not. Maximum displacement of the plates with different rib layouts is then compared taking into account the length of the ribs deployed on the plate: The optimum layout is that satisfying the stiffness requirement while using the minimum overall rib length.

4 Rib modelling

A key point in the proposed optimization strategy is the way of modelling the ribs. In order to study different

Table 2 Bead's inertia properties

Thickness, t (mm)	Plate dimensions		
	I_1 (mm ⁴)	I_2 (mm ⁴)	dz (mm)
1	96.42	70.76	2.625
1.2	103.49	76.41	2.500
1.5	108.44	80.83	2.311
2	104.57	79.26	1.996

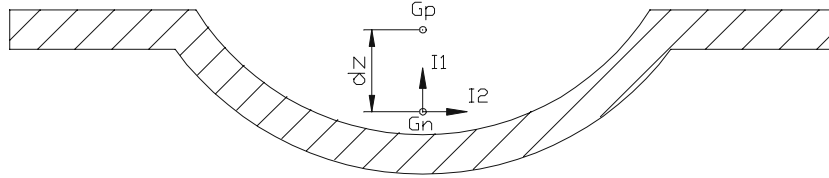

layouts or ribs and their effect on the stiffness of the plate, every plate and rib should be modelled in detail. This would involve a considerably expensive workload because it cannot be automated. So, a simplified strategy for modelling beads and their stiffening effect has been developed.

Once the cross section of the rib is defined (Fig. 1) by the chosen tool and then their inertia properties is set, it is possible to replace the ribs with an equivalent model made of the flat plate plus fictitious beam elements with proper stiffness values (according to [1]) as illustrated in Fig. 2. It is possible to get the same stiffening effect due to a rib by assigning suitable inertia property to the equivalent beam. Therefore, it is necessary to know the stiffness increase of a rib: It is the difference between the inertia moment of a flat plate and the same plate with a rib. The result depends on the thickness of the plate and on the geometry of the rib (which is imposed by the tool and is, therefore, fixed). For verification, FEM analysis was carried out on some

reinforced plates: Comparing the models with the real ribs with the models with the equivalent beam elements, the difference in terms of displacements is less than 5% (Fig. 3).

In the examples provided, we studied some industrial applications where displacements are small and yielding is not admissible. So a simple linear elastic isotropic model was used for the material (in this case, it was steel with elastic modulus 210 GPa and Poisson's ratio 0.3). The modulus is changed during optimization from this value to nearly zero as explained before. The choice to change the elastic modulus instead of the inertia moments is aimed to reduce the number of variables. Each beam is defined by two moments of inertia, the principal moments of inertia: To activate or deactivate a rib, both values must be set to zero. A variable affects only one parameter, so two variables per rib would be required, doubling the variables to be managed. Pre-processing, post-processing and solution were carried out by means of Altair HyperWorks 10.0

Fig. 6 Results, 128 runs

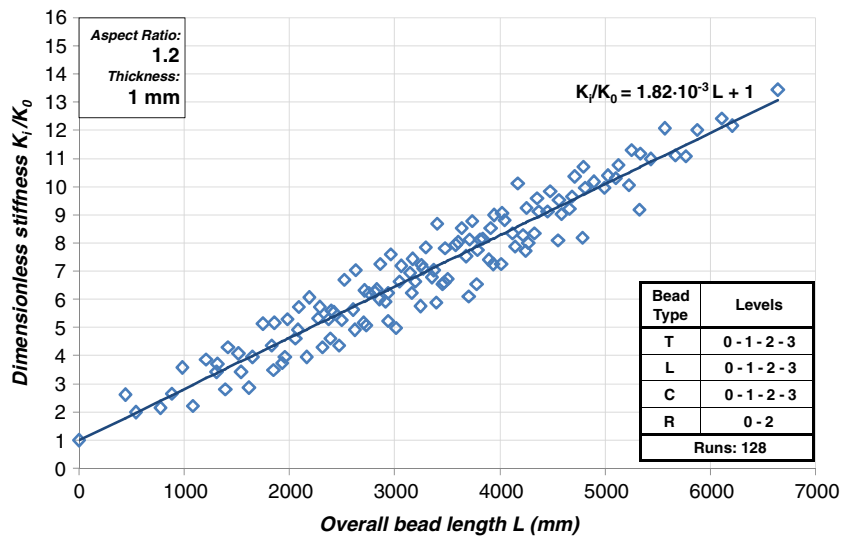
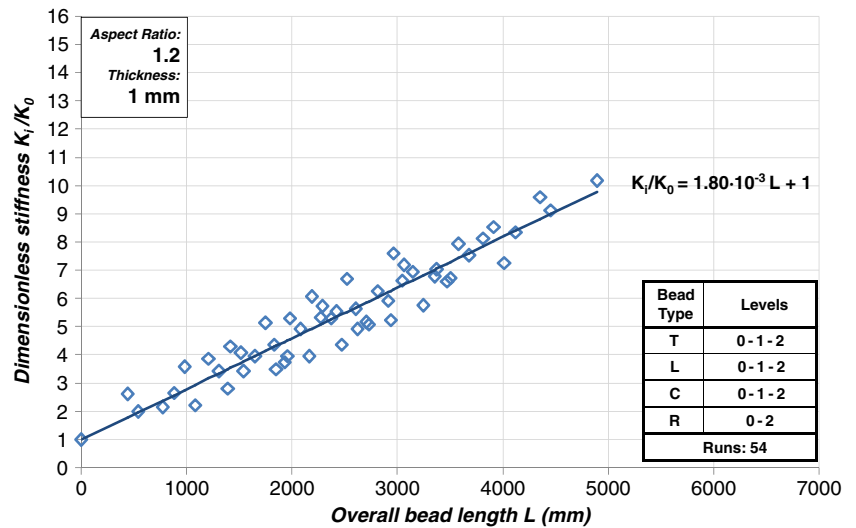

Fig. 7 Results, 54 runs



products and, in particular, the HyperMesh pre-processor, the HyperView post-processor and the Radioss linear solver, respectively.

5 Optimization of rib reinforced plates

The proposed method is illustrated by two case studies. The first one is a rectangular plate with concentrated load in the middle: It is a very simple test case which can easily show the effectiveness of the result. The second one is an industrial application capable to show the interest and the advantages of this approach.

A clarification is necessary at this point. The final result of the design optimization process will be a rib layout extracted from a more complicated layout made of a combination of many simple rib trajectories, as

explained above. The full set of ribs is the starting point of the analysis. In both the following examples, the assumed full set of ribs allow for intersections that, of course, do not respect the technological constraints. In fact, the sheet punching process considered here (Fig. 1) requires that the sheet is flat between the tool. Therefore, it is not possible either to have intersections of any kind or too closely spaced parallel ribs (30 mm in this case). Moreover, it is not possible to have ribs too close to the edges of the plate. However, in the combination with the full set of rib intersections were allowed in order to consider more solutions. Since the methodology turns on and off the ribs individually, it is not sure a priori that in the optimized solution ribs would intersect or not.

In the real plate, that is the layout that could be actually produced, in the case of an intersection there are at least

Fig. 8 Results, 36 runs

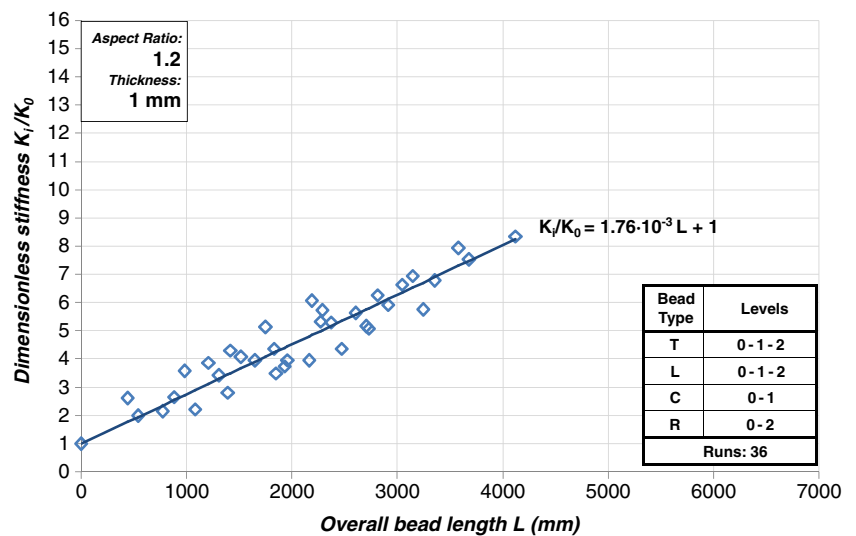
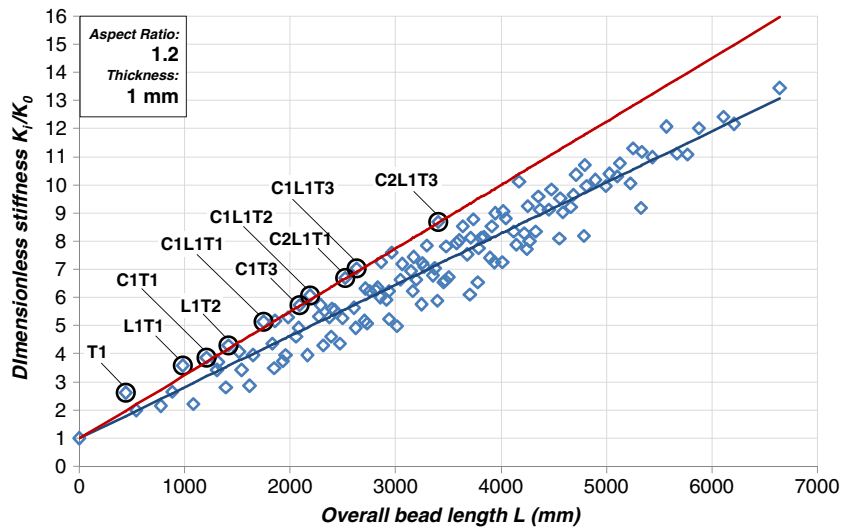

Fig. 9 Results selection from Fig. 6



two possibilities, interrupting one rib or the other. In the case of infeasible layouts with intersections, the most reasonable solution is to perform a posteriori adjustments to eliminate rib intersections: It would be sufficient to interrupt one of the intersecting ribs, eliminating a small part of it, in order to make a layout feasible. The plate stiffness will be, of course, changed and slightly reduced, but, as it has been verified, variations are negligible.

5.1 Plate supported on the boundary and loaded in the middle

In this first example, the bead layout optimization of rectangular plates is described. Moreover, the real ribs have predetermined shape and size so it is not easy to draw general conclusions. For these reasons, dimensions and thickness had to be chosen and were fixed to typical values (four commercial thickness values 1, 1.2, 1.5 and

2 mm). The dimensions were chosen based on these two assumptions:

- Constant global area of the lateral surface:
 $A = 3 \times 10^5 \text{ mm}^2$
- A limited number of four aspect ratios (AR) : 1, 1.2, 1.5 and 2

The four cases are listed in Table 1; multiplied by the four thickness values, it gives a total of 16 combinations of plates studied. For what concerns the boundary conditions, the plate was considered simply supported on the edges (rotation is allowed) and subjected to a normal point load of 100 N in the centre of the plate. Other loading cases and support are possible, and some have also been studied but are not discussed here for sake of simplicity: Exactly the same approach can be used in other cases.

For each one of the 16 combinations of thickness and aspect ratio, the same procedure of stiffness optimization

Fig. 10 Comparison between best results, plate with aspect ratio 1.2

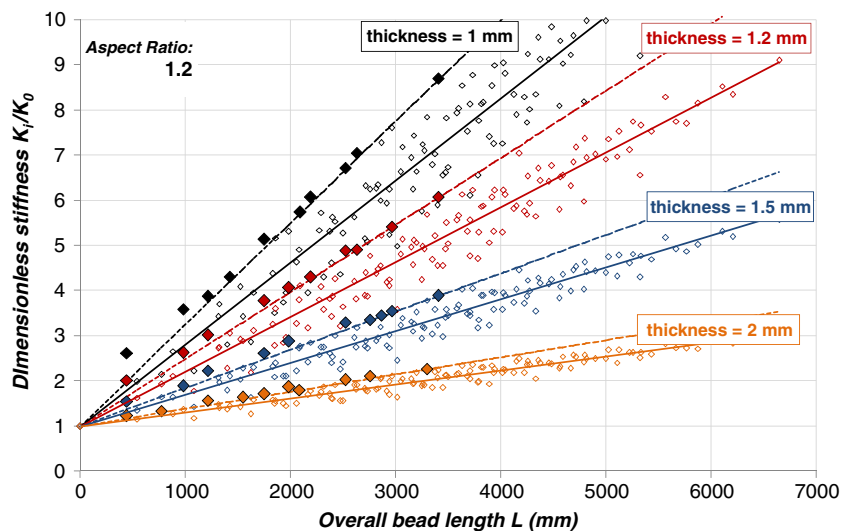
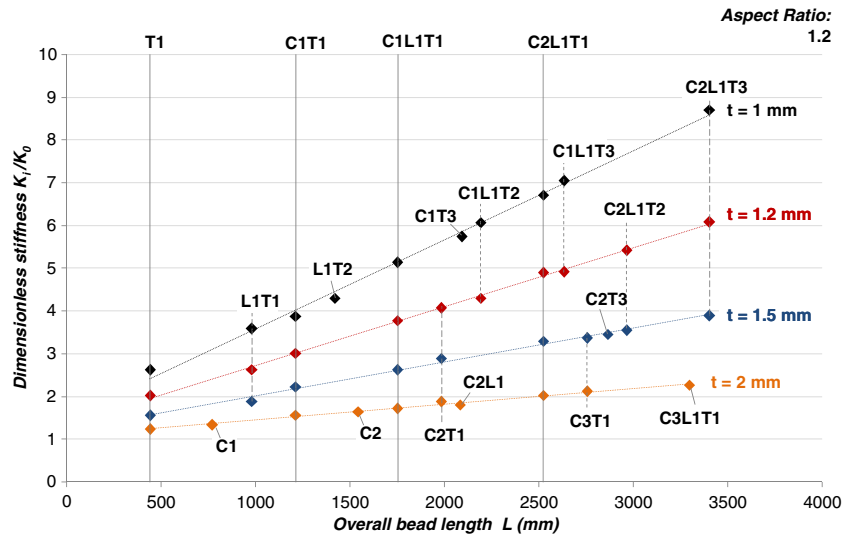

Fig. 11 Common results, aspect ratio 1.2



with different rib layouts was applied. The transverse section of the rib was constant because the same tool was considered for the manufacturing process. Therefore, the objective of the optimization is rib placement.

About rib placement, technological constraints related to manufacturing process were taken into account. In the present case, an electromechanical sheet punching machine was considered: The rib is obtained through a discontinuous punching process that creates the ribs following desired trajectories. The distance within ribs must be greater than a given value in order to allow the punching tool to grab properly the plate. Curvature radius of the rib layouts is limited considering tool trajectory. Also, geometrical layouts like linear and circular (with smooth curvature radius) were preferred in order to simplify tool path trajectory. For each rib shape, there are different levels determined by their number.

The possible rib trajectories are shown in Fig. 4:

- *L* (longitudinal) ribs are those parallel to the longest edge of the plate.
- *T* are those in the perpendicular direction (transverse).
- *R* are placed on the diagonals.
- *C* are elliptically shaped (circular when the plate is a square).

The choice of these rib trajectories was made on the basis of simple considerations on the mechanics of the plate and for the sake of simplicity when coming to the manufacturing phase. Other possible rib trajectories would have been considered but with much greater complication without expected reasonable improvements. In Fig. 4, the levels of variation of the different types of trajectories are shown, starting from the level 0 (corresponding to the

Fig. 12 Best layouts, aspect ratio 1

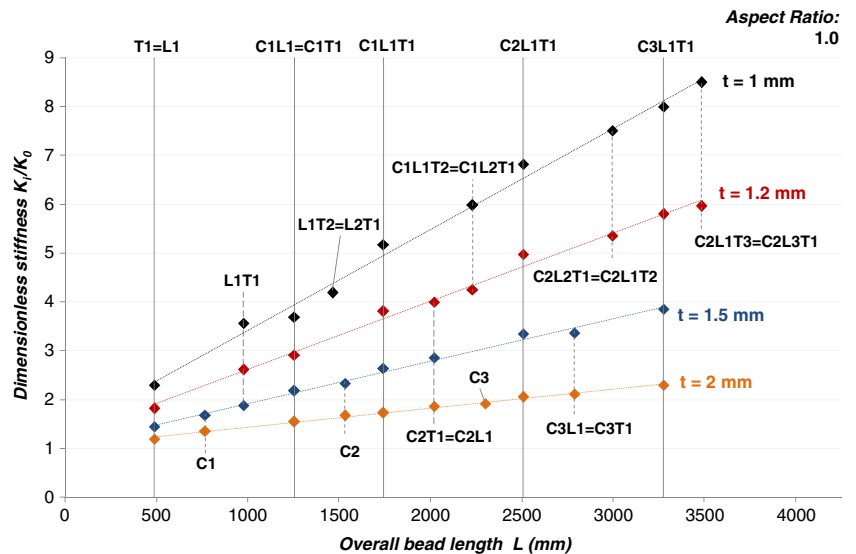
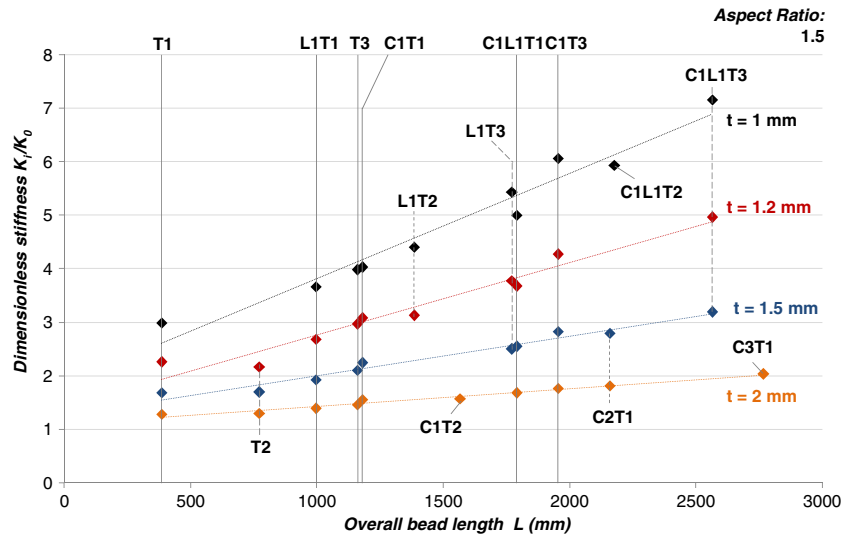

Fig. 13 Best layouts, aspect ratio 1.5



absence of that rib) to a maximum of 3 (in some case). More levels are not considered for two reasons: The ribs would be too tight together (this is not admissible for the manufacturing process as explained), and the number of possible combinations would be exaggerated. Additionally, the number of intersections would be so high to be unmanageable. In Fig. 5, the FE model with the layout including the full set of ribs, that is with all the levels at their maximum value, is shown: The mesh (created in Altair HyperMesh 10.0) consisted of three and four nodes shell elements with average dimension of 5 mm with the ribs replaced by their equivalent beam elements (as described in the previous section: The beams are highlighted with colour lines). The inertia properties of the equivalent beads were calculated with the method described above and listed in Table 2.

Referring to Table 2, I_1 and I_2 are the increase in moment of inertia due to the rib, while dz is the distance

between the centre of gravity of the bead G_n and the one of the flat plate G_p . To evaluate the stiffening brought by the rib layouts, results are graphically shown as in Fig. 6. Figure 6 (relative to a plate with 1 mm thickness and aspect ratio equal to 1.2) plots the results obtained in terms of K_i/K_0 as a function of the overall bead length, where:

- K_i is the stiffness of the plate with a particular layout of ribs (N/mm)
- K_0 is the stiffness of the plate without any rib (N/mm)

In Fig. 6, the results tend to align around a straight line. Each stiffness value, in view of what looks like a statistical spread, can be represented by the analytical expression:

$$K_i = K_0 + \gamma L + e_i$$

Fig. 14 Best layouts, aspect ratio 2

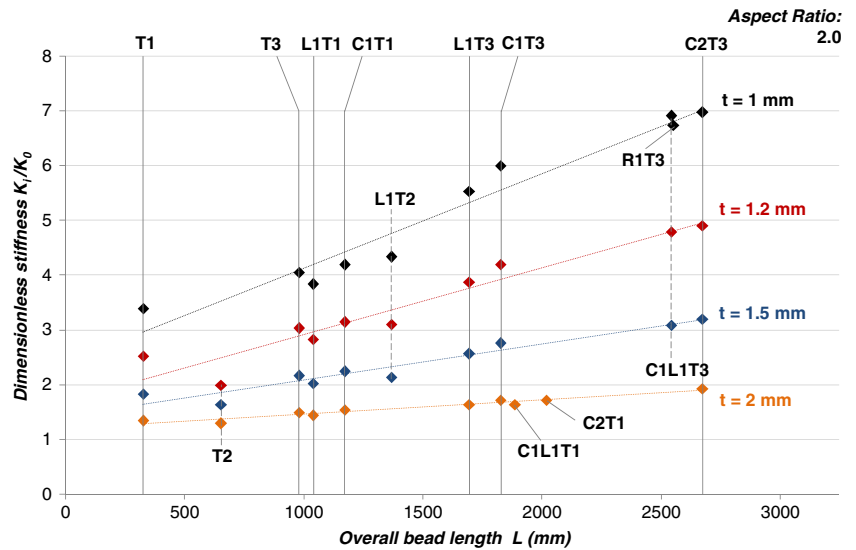
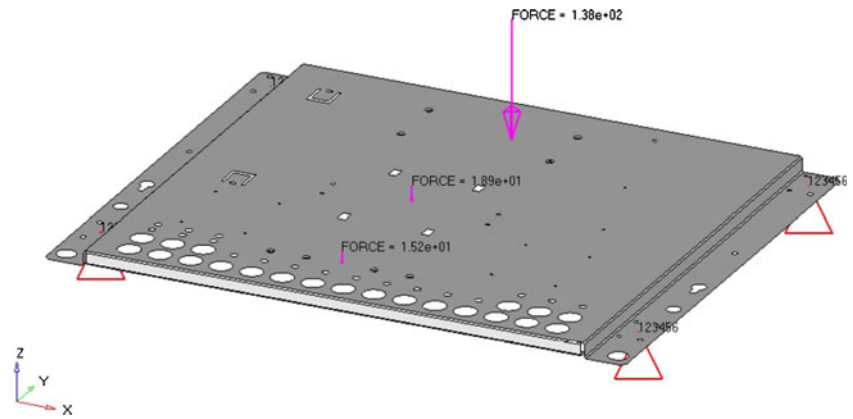

Fig. 15 Motor plate of an industrial refrigerator



where:

- γ is the slope of the trend line
- L is the total length of each rib layout
- e_i is the distance from the trend line, different for every layout

In dimensionless form, the previous expression becomes:

$$\frac{K_i}{K_0} = 1 + \frac{\gamma}{K_0}L + \varepsilon_i$$

In other words, the stiffness can be thought as given by the stiffness of the flat plate plus a coefficient proportional to the total length of the beads and a secondary distinctive contribution of each different layout.

Please note that results shown in Figs. 6, 7 and 8 are clearly related to a subset, though wide, of a theoretically infinite number of possible combinations of ribs on the plate. The spread of the stiffness values is different with different subset of rib layout. Indeed, analysing both cases

with larger and smaller number of levels than in Fig. 6, it comes out a substantial invariance of the slope γ .

As shown in Fig. 6, there are solutions having much different values of K_i/K_0 even with similar lengths. This is a clue of the greater efficiency of some layouts, showing greater stiffness with the same rib length. The more a point is above the trend line, the more that layout is efficient. Since the choice of the optimal solution is not trivial, it is necessary to define a criterion to select the best results. It is not superfluous to repeat that a single optimal result does not exist, since with greater rib length (or more ribs) there will be always a more performance solution.

A possible method is as shown in Fig. 9. A straight line to sort out the most suitable solution is chosen, with intercept equal to $K_i/K_0=1$ and slope greater than the fitting value. Thus, only a certain number of points will be above this sort-out line: It is sufficient to vary its slope to have a chosen number of points above it. In this case, ten results were chosen. Figure 10 shows the best layouts related to

Fig. 16 Static displacements, original plate

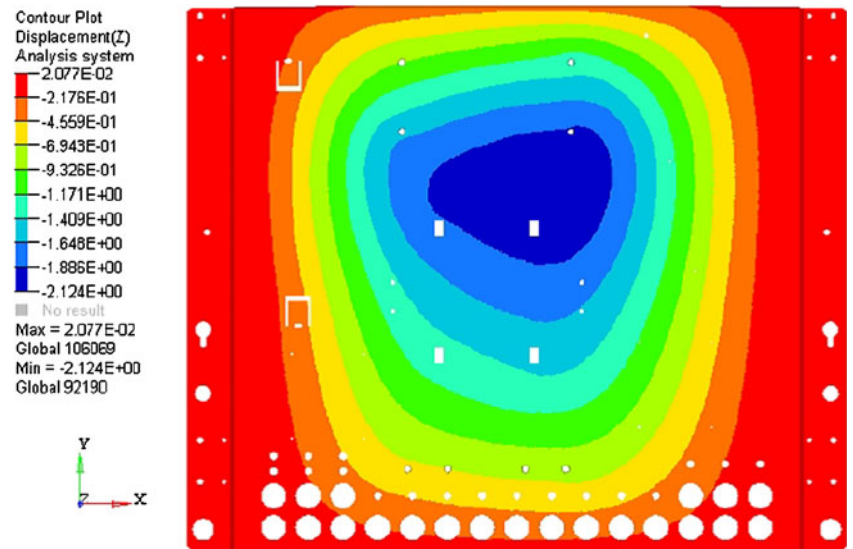
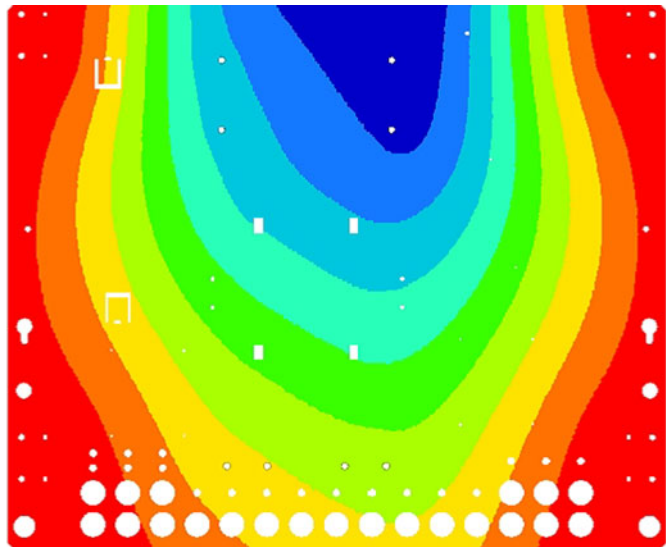
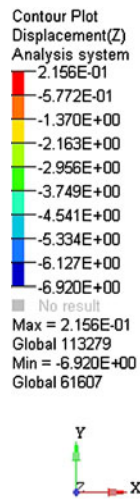

Fig. 17 Static displacements, flattened plate



plates with aspect ratio 1.2 and the different values of thickness defined before, extracted using the method described above. It can be seen that the spread is higher when thickness is lower: Ribs are more effective and the choice of the right solution is more important.

Finally, in Fig. 11, only the best layouts extracted with the described method are compared: This is the design tool that is proposed here. On the basis of the required stiffness or maximum allowable rib length, the most efficient layout is readily obtained from this chart.

It is important to see how, for a plate with fixed dimensions and different thickness, the same layouts are obtained (Fig. 11). The charts in Figs. 12, 13 and 14 illustrate the best layouts for plates with aspect ratios 1, 1.5 and 2.

There is still an apparent indetermination in the results obtained by this method: In fact not an optimal layout but a certain number of more efficient layouts are given. The determination of the best layout depends on the choices of the designer according to the acceptable overall bead length (based upon other kind of considerations, mainly economics) or to the minimum required stiffness.

5.2 Industrial case study

The example relates to the optimization of the motor plate of an industrial refrigerator (Fig. 15), whose function is to support the components of the cooling system. The motor plate is a component made of galvanized laminated steel: In the current production, the plate is 1.5 mm thick. All the refrigerator components are mounted on this plate: Compressor, heat exchanger, cooling fan, condensed water recovery tank and electrical system, in addition to the supporting feet.

Referring to Fig. 15, L-shaped bends are the support of the plate and of the fridge structure; the C-shaped bends on

the remaining edges are structural reinforcements. Boundary conditions represent the normal operating loads: The plate is subjected to the weight of the compressor, the cooling fan and the exchanger assuming that the other parts have negligible weights. The constraints simulate the presence of the supporting feet.

The objective of the study is to eliminate bending operations on the plate replacing them with suitable ribs, in order to simplify manufacturing. A study of thickness reduction was also performed. The stiffness of the new plate must be at least equal to the original one. Static analysis of the component (Fig. 16) shows that maximum displacement is 2.12 mm, located near to the centre of the plate: This is the reference value for the whole study.

The optimized component must be a flat plate with a certain number of ribs; Fig. 17 illustrates static displacements of the flattened component without bending and ribs,

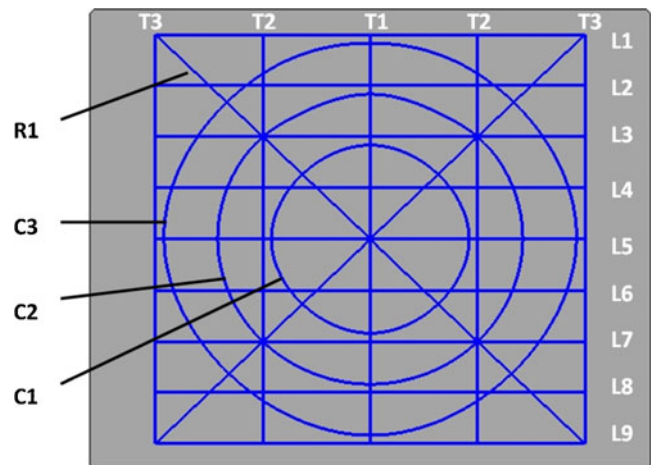
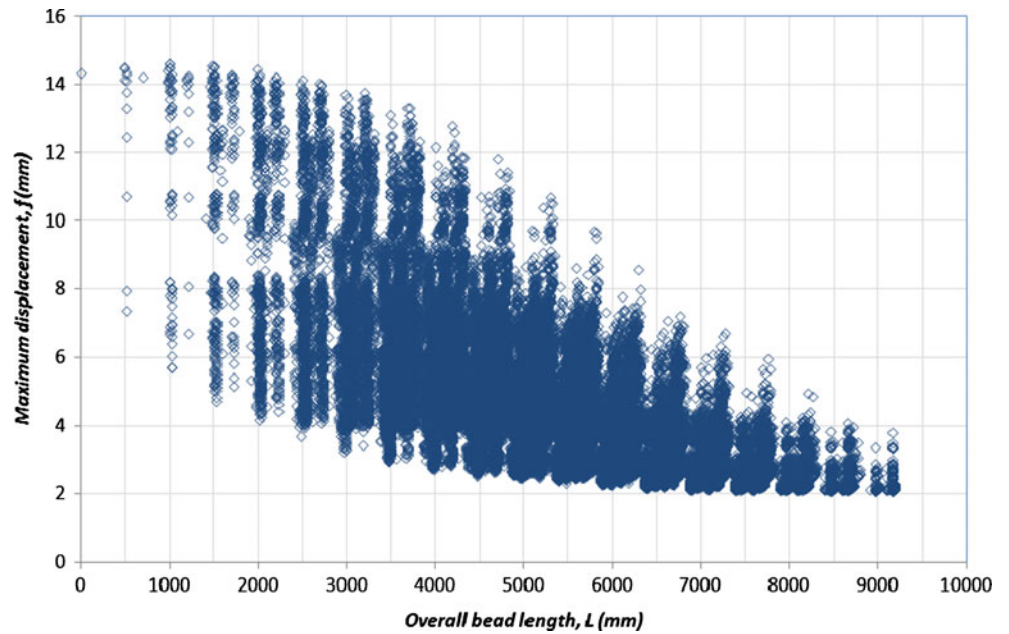

Fig. 18 Complete layout for motor plate optimization

Fig. 19 Results, thickness 1.2 mm



which is the starting point of the optimization. It can be noticed how, by eliminating every bend on the plate, maximum displacement becomes about 6.92 mm, located on the edge of the plate.

Motor plate optimization, using the method described above, was performed on two plates with thickness 1.2 and 1.5 mm. A solution with the same weight and one lighter (20%) were compared.

As in the previously examined problem, it was chosen to use a set of ribs arranged in simple shapes in order to realize them easily, according to the following scheme:

- Longitudinal ribs, *L*: nine levels (aligned with the longest edge direction)

- Transverse ribs, *T*: three levels (with beads symmetrical to the symmetry axis of the plate)
- Circular ribs, *C*: three levels
- Diagonal ribs, *R*: one level

The reason why nine ribs of type *L* were allowed and much less of type *T* is due to the fact that preliminary calculations proved the former type more efficient. *T2* and *T3* ribs are symmetric because load is symmetric with respect to the vertical axis of the plate but asymmetric in the other direction. Possible layouts are any combination of the previously described types of ribs. Figure 18 illustrates how the full pattern of ribs is placed on the plate following the described criteria.

Fig. 20 Best layouts envelope curve, thickness 1.2 mm

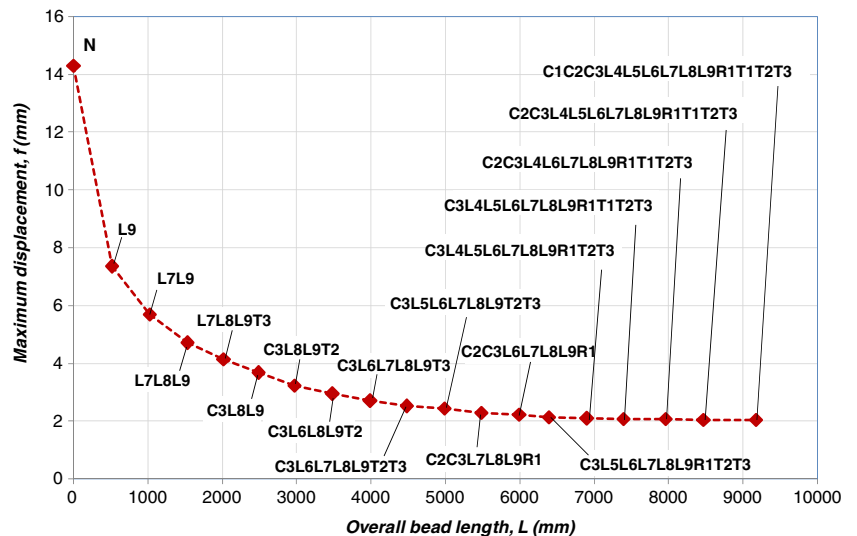

Table 3 Best layouts, thickness 1.2 mm

No.	Layout	Maximum displacement, f (mm)	Beads length, L (mm)
0	N	14.31	0
1	L9	7.36	510
2	L7L9	5.69	1,020
3	L7L8L9	4.70	1,530
4	L7L8L9T3	4.15	2,016
5	C3L8L9	3.67	2,484
6	C3L8L9T2	3.22	2,970
7	C3L6L8L9T2	2.94	3,480
8	C3L6L7L8L9T3	2.70	3,990
9	C3L6L7L8L9T2T3	2.51	4,476
10	C3L5L6L7L8L9T2T3	2.44	4,986
11	C2C3L7L8L9R1	2.30	5,485
12	C2C3L6L7L8L9R1	2.23	5,995
13	C3L5L6L7L8L9R1T2T3	2.14	6,395
14	C3L4L5L6L7L8L9R1T2T3	2.09	6,905
15	C3L4L5L6L7L8L9R1T1T2T3	2.08	7,391
16	C2C3L4L6L7L8L9R1T1T2T3	2.07	7,963
17	C2C3L4L5L6L7L8L9R1T1T2T3	2.05	8,473
18	C1C2C3L4L5L6L7L8L9R1T1T2T3	2.05	9,174

As in the previous example, no yielding is expected and therefore is not taken into account: A simple linear elastic isotropic material model is used. The plate is meshed with shell elements of average size 10 mm.

Rib section is the same of the previous example (Table 2). Sixteen ribs were arranged in the model, and

each one can be independently set on or off. The required analysis was run by a HyperStudy program.

Figure 19 reports the whole set of results in terms of the maximum displacement as a function of the overall rib length. A widespread in the displacement values is noticeable, especially at lower length values: For similar rib lengths,

Fig. 21 Layout comparison

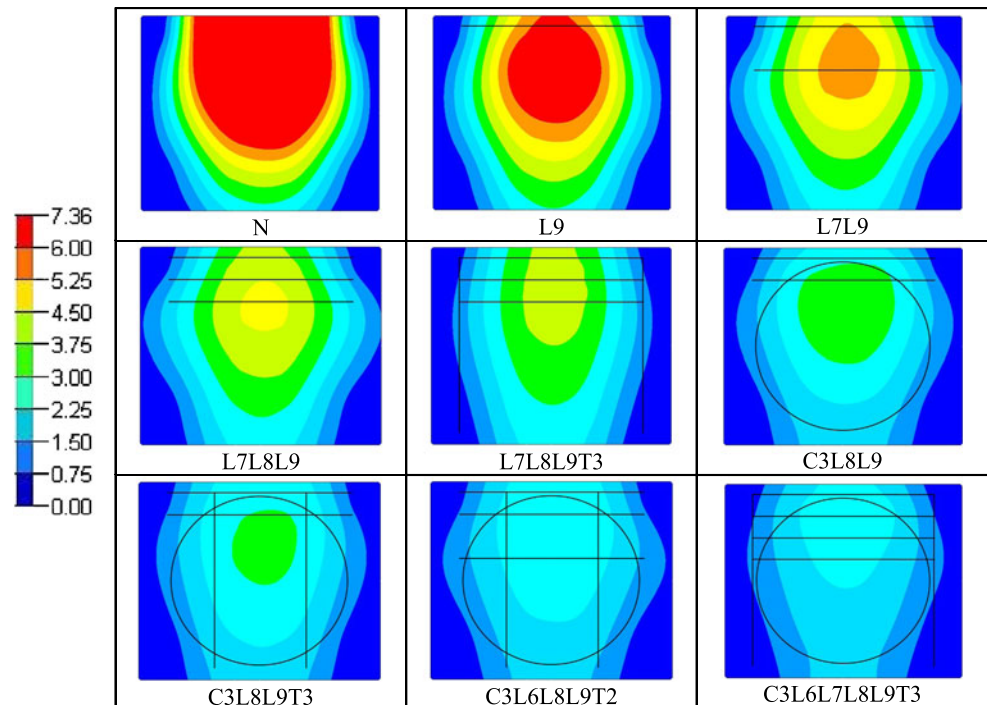
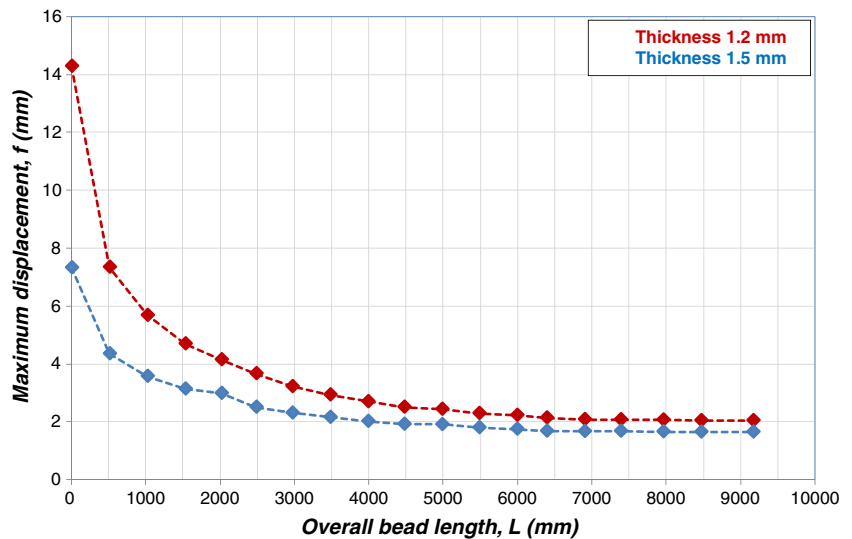

Fig. 22 Comparison between plates with thickness 1.2 and 1.5 mm



there are remarkable variations in maximum displacement. At higher values of rib length, more or less almost all the individual ribs are activated. Instead, there are lots of layouts who give similar results, and in some cases, a small increase in length gives a high increase of stiffness and vice versa. It is therefore necessary to use a criterion in order to reduce the number of solutions and to choose the most efficient.

Since the focus was on stiffness, it was decided to extract an envelope curve with lower displacement. To obtain such envelope, the results are classified by length in ranges of about 500 mm: For every range, the minimum displacement point is extracted, and the resulting minima are plotted in Fig. 20, corresponding to optimal layouts listed in Table 3.

From Fig. 20, it is easy to see how the stiffening effect decreases with the increase in the overall rib length: Shorter ribs appear to be more efficient. Furthermore, the curve shows that in order to have a displacement equivalent to the original plate (about 2.1 mm), at least 6 m of ribs is necessary. Instead, Table 3 put in evidence the increase in complexity of the rib pattern for increasing stiffness. Figure 21 shows a qualitative comparison between the results from plates with different layouts.

With the same procedure, results from the plate with 1.5 mm thickness are reported. Figure 22 shows a comparison between the envelopes for the two thicknesses.

In order to obtain a maximum displacement lower than in the original plate, at least 3 m of ribs is needed. As a pure example, two possible solutions are listed in Table 4.

6 Conclusions

A simple methodology for the design of an optimal layout of reinforcement ribs in the presence of technological constraints has been proposed. Technological constraints

complicate the problem in the definition of the problem according to classical optimization procedures. Moreover, in industrial applications, only subsets of relatively simple rib shapes are acceptable. Simple rules of thumb for layout selection are preferred or applicable, more than precise but unpractical optimal solutions.

Differently from classical optimization methods that aim to find the rib layout automatically, in this case the trajectories for the ribs are assumed a priori according to feasible layouts. The evaluation criteria adopted allow to obtain subsets of efficient layouts, for given rib length. The rib layout satisfying the stiffness requirements once minimizing the overall rib length will be the solution of the optimization problem. Eventually, to take into account unfeasible rib intersections, a post-processing can be made to eliminate it. The criteria for the selection of optimal layouts have been described, and they constitute a useful tool for design purposes.

The proposed method, illustrated by the layout optimization of a rectangular plate under transverse load (with different values of the aspect ratio and thickness), was then applied to a typical industrial product. The examples proved the efficiency and feasibility of the procedure. Of course the method, which is based on predetermined layouts and a selection among them, is not guaranteed to give the absolute optimum and not to exclude some better solution but certainly gives good results for practical purposes.

Table 4 Optimization solutions

Layout	Thickness, t (mm)	Max displacement, f_{\max} (mm)	Beads length, L (mm)
C2C3L6L7L8L9R1	1.2	2.23	5,995
C3L6L8L9T2	1.5	2.16	3,480

Acknowledgements The authors gratefully acknowledge the financial support of Regione Piemonte through grant no. 427/2009 “RefriFleX” within the frame of the Regional Program D.D. 44/2008 for the support of Industrial Research Project and Experimental Development in Advanced Production Systems. The support of MondialGroup represented by Gianni Gonella, Claudio Fossati, Daniele Vairo, and Marzio Caligaris is also kindly acknowledged.

References

1. Yang RJ, Chen CJ, Lee CH (1996) Bead pattern optimization. *Struct Optim* 12:217–221
2. Zhou M, Pagaldipti N, Thomas HL, Shyy YK (2004) An integrated approach to topology, sizing, and shape optimization. *Struct Multidiscipl Optim* 26:308–317
3. Chung J, Lee K (1997) Optimal design of rib structures using the topology optimization technique. *Proc Inst Mech Eng Part C J Mech Eng Sci* 211:425–437
4. Luo JH, Gea HC (1998) Optimal bead orientation of 3D shell/plate structures. *Finite Elem Anal Des* 31:55–71
5. Díaz AR, Lipton R, Soto CA (1995) A new formulation of the problem of optimum reinforcement of Reissner–Mindlin plates. *Comput Meth Appl Mech Eng* 123:121–139
6. Lam YC, Santhikumar S (2003) Automated rib location and optimization for plate structures. *Struct Multidiscipl Optim* 25:35–45
7. Park MY, Park Y, Park YS (2007) Raising natural frequencies of a structure via surface-grooving technique. *Struct Multidiscipl Optim* 34:491–505