

Displacement and acceleration measurements in vibration tests using a fiber optic sensor

*Original*

Displacement and acceleration measurements in vibration tests using a fiber optic sensor / Vallan, Alberto; Casalicchio, MARIA LUISA; Perrone, Guido. - In: IEEE TRANSACTIONS ON INSTRUMENTATION AND MEASUREMENT. - ISSN 0018-9456. - STAMPA. - 59:5(2010), pp. 1389-1396. [10.1109/TIM.2010.2040934]

*Availability:*

This version is available at: 11583/2317569 since:

*Publisher:*

Institute of Electrical and Electronics Engineers

*Published*

DOI:10.1109/TIM.2010.2040934

*Terms of use:*

This article is made available under terms and conditions as specified in the corresponding bibliographic description in the repository

*Publisher copyright*

(Article begins on next page)

© 2010 IEEE. Personal use of this material is permitted. Permission from IEEE must be obtained for all other uses, in any current or future media, including reprinting/republishing this material for advertising or promotional purposes, creating new collective works, for resale or redistribution to servers or lists, or reuse of any copyrighted component of this work in other works.

**Displacement and Acceleration Measurements in Vibration Tests Using a Fiber Optic Sensor**

A. Vallan, M.L. Casalicchio, G. Perrone

Published in: Instrumentation and Measurement, IEEE Transactions on (Volume:59 , Issue: 5 )

Date of Publication: May 2010

Page(s): 1389 - 1396

ISSN : 0018-9456

INSPEC Accession Number: 11208294

Digital Object Identifier : 10.1109/TIM.2010.2040934

Sponsored by : IEEE Instrumentation and Measurement Society

# Displacement and Acceleration Measurements in Vibration Tests Using a Fiber Optic Sensor

Alberto Vallan, *Member, IEEE*, Maria Luisa Casalicchio and Guido Perrone, *Member, IEEE*

**Abstract**—The paper discusses the evaluation of displacements and accelerations from non-contact displacement measurements using a low-cost plastic fiber optic sensor. Issues about the sensor calibration in the presence of non-uniform targets, a situation occurring in many practical applications like vibration tests of printed circuit board assemblies, are analyzed. Furthermore, a procedure to contemporaneously calibrate several optical sensors to allow mapping the vibration amplitude and acceleration distributions in a simple and low cost way is also disclosed. The proposed calibration procedure is particularly effective since it requires just one reference accelerometer, which is actually already available in typical vibration test facilities. Experimental results obtained in real conditions during a sinusoidal vibration test are also provided.

**Index Terms**—Optical Fibers, Plastic Optical Fibers (POF), Optical Sensors, Acceleration measurements, Vibration tests.

## I. INTRODUCTION

Vibration tests play a major role in studying the dynamic behavior of components and equipments and

M.L. Casalicchio, G. Perrone and A. Vallan are with the Dipartimento di Elettronica, Politecnico di Torino, corso Duca degli Abruzzi, 24 - 10129 Torino (Italy); phone: +39 011 5644110, fax: +39 011 5644217, e-mail: alberto.vallan@polito.it This work has been supported by Piemonte local government within the MAESS-2006 project "Development of a standardized modular platform for low-cost nano and micro satellites and applications to low-cost space missions and to Galileo".

in verifying their capability to withstand mechanical stresses. These tests are typically carried out using shakers controlled by suitable systems that force known accelerations according to specific Standards, like the IEC 60068-2-6 for sinusoidal tests. In these cases the acceleration is usually sensed by piezoelectric accelerometers: typically at least one of these sensors is firmly attached to the shaker vibrating table using screws or stickers to measure its acceleration, but often many other sensors are placed also on the device under test to study the onset of resonances. In many situations the effects due to dimension and weight of these sensors can be neglected, since very small devices with weight even below 1 g are available. However, applications exist where even the smallest and lightest devices introduce unacceptable perturbations or cannot be placed because of lack of space; a common example is the vibration test of printed circuit boards already populated by electronic components. Often, these are also the typical applications where it is necessary to measure the vibration amplitude in several points and this would require many sensors working simultaneously, in order to maximize the measurement speed or acquire the shape of the vibration modes. Therefore it would be desirable to have a non-contact acceleration sensor - the only one that really do not introduce perturbations - with low fabrication costs to enable its simple replication to fabricate multi-

points sensing heads. Using non-contact sensors, the acceleration can be computed from a measure of distance, evaluating the variations of position of the vibrating surface with respect to a fixed sensing head. The maximum vibration frequency at which this technique can be used is limited by the minimum detectable distance variation, since displacements become smaller as the frequency increases. For example, in the specific case of printed circuit boards, it is necessary to measure distances in the millimeter range, with a sub-micrometric resolution, at frequencies up to few hundred of hertz, in order to have resolution in acceleration below  $1 \text{ m/s}^2$ .

Optics is known to represent an effective approach for non contact distance measurements and thus several optical techniques have been proposed in the literature, such as interferometry [1], [2], laser Doppler vibrometry [3], [4] and self-mixing interferometry [5]. All these approaches are characterized by excellent performances, but either require complex and expensive setups or are somehow cumbersome to apply and therefore are not well suited to map the vibration amplitude in several test points. On the other hand, intensity-based fiber optic sensors are known to allow the measurement without contact of short distances in a cost effective way, especially if plastic optical fibers (POF) are used instead of more common glass fiber bundles [6]-[9]. POF have very high light collecting capability since they have larger diameter and larger numerical aperture. This also simplifies the fiber handling because POF have less stringent requirements for alignments and connections [10]. In particular a low-cost fiber vibrometer can be realized using only two optical fibers: one fiber lights the target and the other collects the reflected beam, exploiting the dependence of the collected light intensity with distance. Unfortunately, this type of sensor is also sensitive to the target optical characteristics, so it requires a calibration before

each usage. Several compensation techniques have been therefore developed to overcome this drawback, but all the proposed approaches still fail in the presence of a non-uniform target reflectivity.

This paper proposes a measurement technique specifically conceived to allow using the low-cost fiber optical sensor already presented in [6] also with targets having non-uniform reflectivity or non-flat surface profile. Indeed, the sensing system in [6] can cope with targets having different values of reflectivity (also changing during the measurement process), but only if the target surface is flat and its reflectivity remains uniform. Therefore, the approach in [6] is not suitable for evaluating the vibration amplitude of targets having a non-spatially uniform reflectivity or thickness, such as in the case of printed circuit boards that will be described in the following section. Moreover, using the novel approach, the problem of the sensor calibration is simplified because just a single traditional accelerometer, which is almost always available in any vibration facilities, is employed as a reference sensor.

## II. SENSOR WORKING PRINCIPLE AND CALIBRATION ISSUES

The schematic block diagram of the proposed non-contact optical sensor is shown in Fig. 1, where a

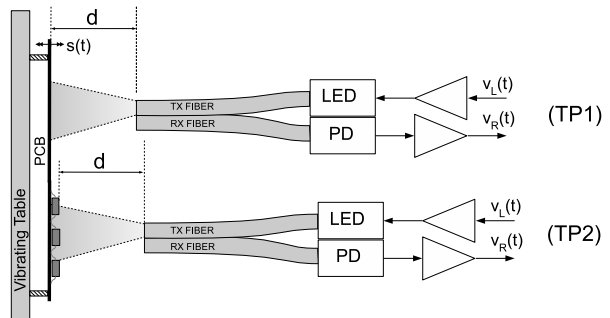

Fig. 1. The optical sensor structure.

couple of them is employed to measure the vibration on a printed circuit board (PCB) in two different points representative of typical situations. Test point TP1 is in a region where the surface can be considered flat, although may presents non-uniform reflectivity, while in the case of test point TP2 the surface is not even uniformly thick due to the presence of electronic components.

The sensor working principle is based on the measurement of light intensity reflected by the vibrating target and that depends on the sensing head to target distance. More in detail, the sensing heads are composed of a transmitting fiber, which routes the light to the target, and a receiving fiber, which collects the light reflected by the target. The transmitting fiber is fed by a LED (like in this experimental implementation) or by a low-cost laser diode, while the receiving fiber is connected to a photodetector (PD) followed by a suitable amplifier that converts the detected current into the voltage  $v_R(t)$ .

The received voltage  $v_R(t)$  can be written as:

$$v_R(t) = A \cdot \frac{P_R(d)}{P_T} v_L(t) \quad (1)$$

where  $P_R(d)/P_T$  is the ratio of the optical powers at the transmitting and receiving fiber tips, including the effect of the target reflectivity, and the term  $A$  takes into account the amplifier gains, the fiber losses, and the LED and PD efficiencies.

When the target displacement due to the vibration is small with respect to the working distance  $d_0$ , the optical power ratio can be expressed using a linear approximation as [6]:

$$\begin{aligned} \frac{P_R(d)}{P_T} &\cong R_{eq} \cdot [R_0 + R_1 \cdot (d - d_0)] = \\ &= R_{eq} \cdot [R_0 + R_1 \cdot s(t)] \end{aligned} \quad (2)$$

where  $R_{eq}$  acts as a multiplicative factor and it is the equivalent reflectivity of the area lighted by the transmitting fiber. The coefficients  $R_0$  and  $R_1$  are the optical power ratio computed for unit reflectivity and

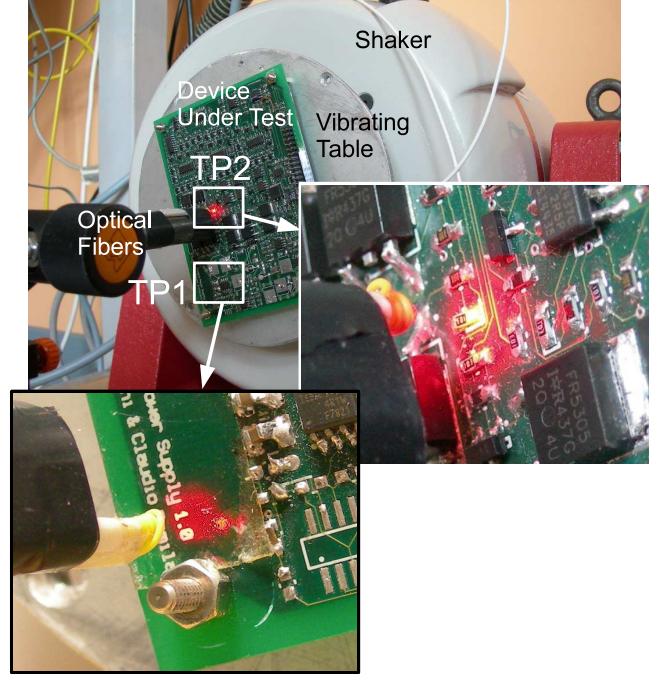

Fig. 2. The device under test (a printed circuit board) during the vibration test and the optical fibers. The test points TP1 and TP2, where the acceleration has to be measured, are highlighted.

its first derivative, respectively, both evaluated at the working distance  $d_0$ . The received signal can thus be written as a function of the target vibration amplitude  $s(t)$ , measured around the steady state  $d_0$ , and of the LED stimulus  $v_L(t)$  as:

$$v_R(t) = A \cdot v_L(t) \cdot R_{eq} \cdot [R_0 + R_1 \cdot s(t)] \quad (3)$$

The choice of the most suitable LED driving signal depends on the application and this problem has already been addressed in other papers [6], [11]. The simplest choice is based on a constant stimulus  $v_L(t) = V_L$ , yielding to the following received signal:

$$\begin{aligned} v_R(t) &= A \cdot R_{eq} \cdot V_L \cdot R_0 + A \cdot R_{eq} \cdot V_L \cdot R_1 \cdot s(t) = \\ &= V_{DC} + k \cdot s(t) = V_{DC} + v_{AC}(t) \end{aligned} \quad (4)$$

The received signal is composed of a DC term, and of an AC term proportional to the vibration signal

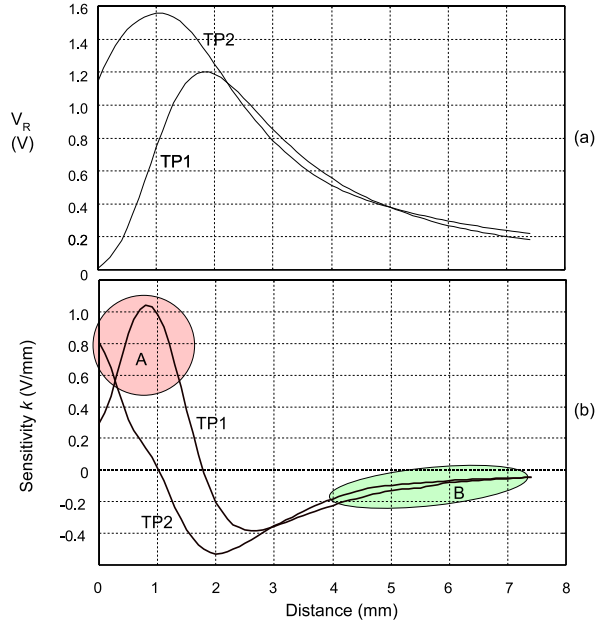

Fig. 3. The measured received signals (a) and the sensor sensitivity (b) at the test points TP1 and TP2 as a function of the distance between the fiber tips and the target and in absence of vibrations.

$s(t)$  through a scale factor  $k$  that represents the sensor sensitivity and that depends on amplifier gains and fiber losses, on the equivalent surface reflectivity, the LED driving voltage and the first derivative of the optical power ratio.

Sensors of this kind are typically calibrated applying a known displacement  $s(t)$  and measuring the corresponding AC output signal in order to determinate the sensor sensitivity. The displacement can be obtained either by means of a calibrated micro positioning stage [7] or using a different measuring system such as a Linear Variable Differential Transformers (LVDT) [9] or laser interferometers [12]. Anyway, in practical applications, the vibrating target can be different from the one employed to calibrate the sensor and it is not always possible to perform the calibration applying a reflecting surface on the device under test [12]. Several approaches have been proposed to measure the displacement trying to over-

come the problem of a different surface reflectivity, such as those based on fiber bundles [7],[13], on modulated optical signals [6],[12] or taking advantage of the sensor theoretical optical model [14]. These approaches provide satisfactory results in the presence of uniform targets, but they fail when the target surface is not uniform.

An example of such a problem can be obtained considering the setup in Fig. 2 used to measure the acceleration simultaneously in two points on a printed circuit board (PCB).

The sensors in Fig. 2 have been characterized, in the absence of vibrations, in the 0 mm (fiber tips in contact with the target, see also Fig. 1) to about 8 mm range, obtaining the curves reported in Fig. 3, where the received voltage  $V_R$ , which is directly proportional to  $P_R/P_T$ , is reported for the two sensors. In both cases the distance  $d$  is measured from the fiber tips to the target surface and is zero when the tips are in contact with the most prominent part of the target. As shown in Fig. 3, both the received power level and its relation with the distance are strongly dependent on the test point. In the case of uniformly thick targets (as in TP1), when the fiber tips are in contact with the target ( $d \simeq 0$ ), the received light is almost negligible because the light from the transmitting fiber cannot reach the receiving fiber. The sensor behavior can be modeled using one of the proposed approaches [9],[15],[16]. On the contrary, for targets having a non-uniform thickness, the received power may be significant even at  $d \simeq 0$  (as for TP2) because in that case the receiving fiber tip is partially lit from the beam reflected by the “valleys” of the surface. Then the two curves in Fig. 3 have also a different shape because of the presence of surface mounted devices at the test point TP2, and this effect can be hardly modeled since in a general case the devices thickness is not uniform and depends on the region lit by the transmitting

fiber. Finally, the remarkably different peak amplitudes are due to the different reflectivity at the two test points (in particular the presence of some weld points in TP2 causes a sparkling surface behavior and this accounts for a higher peak of the received power in that case).

The sensor sensitivity [6] is shown in Fig.3(b) and it is proportional to the term  $R_1$ , which is the first derivative of the curves in Fig. 3(a). It is evident that each sensor has a different sensitivity, which depends both on the distance and on the target point. Hence, it is not possible to extend the characterization results from one test point to others, and thus each point has to be characterized separately. However, this is expensive and time consuming and, therefore, this approach can be hardly employed in real applications.

The alternative calibration presented in the following section has been devised to simplify the sensor calibration and it can be employed, without additional efforts, even when several optical sensors are used contemporaneously to map the vibration distribution of non-uniform targets.

### III. CALIBRATION TECHNIQUE BASED ON A REFERENCE ACCELEROMETER

The proposed calibration procedure takes advantage of the accelerometer that is already employed to control the shaker and that acts here as a reference sensor. The vibration amplitude is derived from the acceleration measurements and it is employed to calibrate the optical sensor.

According to (4) the target displacement can be obtained dividing the AC voltage  $v_{AC}(t)$  by  $k$ , which is unknown, but which can be considered constant provided that the average distance  $d_0$ , the LED stimulus  $V_L$ , the amplifier gains  $A$  and the target reflectivity do not change significantly during the test. Moreover,  $k$  can

be considered independent from the vibration frequency since the amplifiers can be designed to have a much larger bandwidth than that concerning the vibration test. Thus,  $k$  can be easily obtained measuring the displacement  $s(t)$  and the corresponding sensor output  $v_{AC}$  at any arbitrary vibration frequency,  $\omega_c$ . In the proposed approach, the shaker is employed to force a sinusoidal vibration and the displacement is obtained processing the acceleration measured by the reference accelerometer. In these conditions the acceleration can be written as:

$$a(t) = A_P \cdot \sin(\omega_c \cdot t) \quad (5)$$

being  $A_P$  the peak value of the acceleration. Therefore the displacement becomes:

$$s(t) = -\frac{A_P}{\omega_c^2} \cdot \sin(\omega_c \cdot t) \quad (6)$$

and thus the output signal is:

$$v_{AC}(t) = k \cdot s(t) = -k \cdot \frac{A_P}{\omega_c^2} \cdot \sin(\omega_c \cdot t) \quad (7)$$

The absolute value of the sensor sensitivity  $k$  can be obtained measuring the peak amplitudes  $V_P$  and  $A_P$  of the detected signal  $v_{AC}(t)$  and of the acceleration signal  $a(t)$  respectively:

$$k = \frac{\omega_c^2 \cdot V_P}{A_P} \quad (8)$$

whereas the sign of  $k$  can be detected by observing signals  $v_{AC}(t)$  and  $a(t)$  in the time domain, although in several applications the sign is not relevant.

After the scale factor has been obtained, the actual displacement can be measured from the sensor output as:

$$s(t) = v_{AC}(t)/k \quad (9)$$

The acceleration can be eventually obtained processing the displacement in a numerical way. In case of sinusoidal vibration tests it is straightforward, while in a more general case the presence of noise requires accurate

filtering and suitable numerical techniques such as that presented in [17].

The scale factor in (8) has been determined forcing sinusoidal vibrations, condition that can be easily obtained since modern shakers can be controlled to produce sinusoidal accelerations with a low distortion. However, residual distortion, noise and electrical and optical disturbances can affect the measurements of both the acceleration and the output signals amplitudes thus impairing the calibration result. These problems can be reduced post-processing the acquired data, for example extracting the first harmonic component using a synchronous detection technique, as the one employed in the experimental tests. There are, however, other aspects of the calibration procedure (e.g. the choice of the accelerometer position, of the calibration frequency  $\omega_C$  and of the optical sensor distance) that can strongly impact on the calibration uncertainty: their effects are discussed in the next paragraphs.

#### *A. Choice of the accelerometer location and of the calibration frequency*

According to the proposed calibration procedure, the acceleration and the displacement have to be measured at the optical sensor location, requiring to place the accelerometer very close to the optical sensor. However, if the vibration frequency is low enough, well below the resonances of the mechanical system under test, the acceleration can be considered constant in any point and it can be measured using a single accelerometer placed at any position, not necessarily coincident with a test point [12]. Moreover, being the acceleration constant over the vibrating table, the same accelerometer can be employed to simultaneously calibrate several optical sensors distributed over the table.

In real applications, however, the choice of the cali-

bration frequency has to be carried out by taking into account aspects besides the vibrating table resonances. Both the accelerometer and the optical sensor have, typically, AC coupled conditioning circuits so their frequency response can affect the calibration results when low frequency signals are employed. For this reason, in practice, calibration frequencies below few hertz can not be employed.

In addition, systematic calibration errors can appear at low frequencies because of the nonlinear response of the optical sensor. Actually, the vibration amplitude remarkable increases by reducing the frequency (6) since the acceleration can not be arbitrarily reduced. As shown in Fig. 3(a), the sensor output has a nonlinear behavior with respect to the distance, so the output signal is affected by a significant distortion when the vibration amplitude increases. The distortion effects have been evaluated using the theoretical optical model shown in [15], and it has been proven that for a working distance  $d_0$  between 4 mm and 10 mm the error on the sensitivity value obtained using Eqn. 8 is below 1% if the displacement is kept below 0.6 mm. This means that if an acceleration value of  $10 \text{ m/s}^2$  is employed to perform the sensor calibration, the minimum calibration frequency must be greater than 20 Hz.

#### *B. Choice of the optical sensor distance and effects of distance drifts*

The choice of the sensor distance is another aspect that affects both the sensor performance and the calibration effectiveness, since the sensor sensitivity depends on the target distance, as shown in Fig. 3(b). The figure also highlights that the maximum sensitivity (area A) can be obtained working at shorter distances, i.e. where the fiber tips are close to the vibrating target. Moreover, in these conditions the light spot is small [16] so, local

measurements can be performed. Anyway, in several practical applications, it is better to work at larger distances (area B, in Fig. 3(b)), since it is possible to measure broader vibrations while maintaining the sensor distortion low, even though the sensor sensitivity is lower. Furthermore, in this region the sensitivity shows a lower dependence on the distance than in the previous case. This aspect is particularly important because the sensor distance can not be kept constant neither during the calibration, nor during the test because of the shaker instabilities. As a consequence, the sensor sensitivity can change during the test. This problem can be solved controlling the shaker not only to force known accelerations but also to maintain a steady average position. Such a solution, however, would require other sensors to monitor these quantities, since the accelerometers do not provide any information about the table position. On the contrary, the technique presented in this paper can be used also to overcome this limitation because the same optical sensor that is employed to measure the vibrations can be used also to have an estimation of the table position drifts. Indeed, whereas the AC output signal provides information about the vibration amplitude, its DC component,  $V_{DC}$ , provides information about the target distance, because it is proportional to the received light that, in turn, depends on the distance as shown in Fig. 3(a). Unfortunately, this DC component is affected by offset errors and the relationship with the distance is unknown since the term  $R_0$  in Eqn. 4 is unknown. Anyway, the quantity of interest is the distance variation  $\Delta d$  from the calibration position, which can be measured recording, during the test, the changes  $\Delta V_{DC}$  of the DC component. The variation of the target distance can be thus estimated as:

$$\Delta d = \Delta V_{DC}/k \quad (10)$$

being  $k$  the same sensitivity coefficient already obtained with the calibration procedure.

Using this approach, it is thus possible to measure the changes of the target distance and, if necessary, to correct the sensor sensitivity accordingly. To this aim, preliminary tests can be carried out to highlight how the sensitivity changes with distance around the working point. An example of sensitivity correction performed using this experimental procedure is shown in the section about the results.

#### IV. EXPERIMENTAL RESULTS

Some optical sensors have been arranged in order to prove the effectiveness of the proposed calibration technique. The optical part of each sensor (sensing head) is composed of two step-index Polymethyl-Methacrylate (PMMA) POF having a core diameter of 0.98 mm, an external diameter of 1 mm and a length of a couple of meters. High intensity LEDs driven at a constant current have been employed as sources, and custom made circuits, whose general structure is sketched in Fig. 4, have been used for the receivers. The received signal is firstly amplified using a transimpedance amplifier (A) having a gain of about 1 M $\Omega$ , and its output,  $v_{DC}$ , is employed to measure the distance changes during the test. Then, the DC component is removed from  $v_{DC}$  and the remaining component is further amplified about 60 times (stage B). This second stage implements also a low-pass filter, whose cut-off frequency has been set to about 4 kHz. The output noise measured in dark conditions is of about 0.8 mV<sub>RMS</sub>.

The first tests described in this section have been carried out using the setup shown in Fig. 5 where the accelerometer is directly fixed on the vibrating table and the optical sensor is positioned very close to the accelerometer to ensure that both sensor are subjected

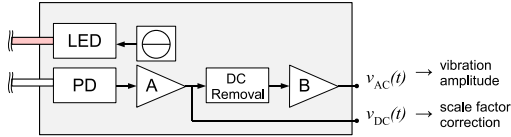

Fig. 4. The structure of the custom-made conditioning circuit.

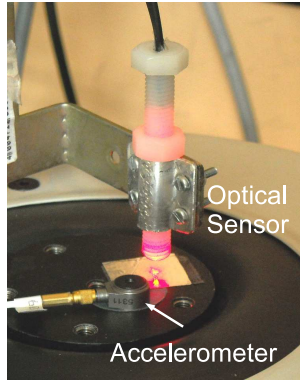

Fig. 5. The arranged optical sensor and the piezoelectric accelerometer.

the same vibrations. A high reflectivity target has been employed to increase the power level of the detected signal. Other experiments have been performed testing the PCB shown in Fig. 2, and in these cases the target reflectivity has not been modified.

The reference accelerometer is based on a commercial piezoelectric sensor having a sensitivity of 10.3 mV/g and a frequency response flatness of  $\pm 5\%$  up to 5 kHz. The optical sensor outputs and the accelerometer signal have been acquired with a 18 bit-digital acquisition board. Working with sinusoidal signals, the voltage peak amplitudes have been measured processing the acquired signals with a DFT algorithm in order to extract the first harmonic components. The acquisition time has been set to 1 s. Special care has been devoted to arrange a steady optical sensor stand to reduce errors due to the sensor vibrations.

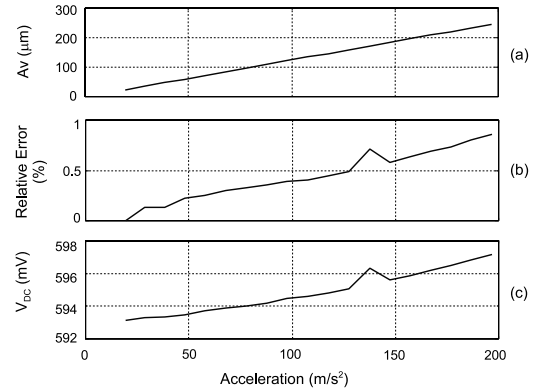

Fig. 6. Experimental results obtained at constant frequency (143 Hz) for different accelerations: (a) measured vibration amplitude (b) relative difference between the optical sensor and the accelerometer outputs (c) average value of the detected optical signal  $v_{DC}$ .

#### A. Effect of the target distance changes

This test has been carried out using the setup of Fig. 5, forcing a sinusoidal vibration at 143 Hz with increasing amplitudes from 20 m/s<sup>2</sup> to 200 m/s<sup>2</sup>. The sensor has been calibrated at the beginning of the test resulting in a sensitivity of about 15.5 mV/ $\mu$ m. Fig. 6(a) shows the measured vibration amplitude, which ranges from about 25  $\mu$ m to 250  $\mu$ m, as expected. Fig. 6(b) shows the difference between the acceleration computed from this amplitude and the accelerometer output, which acts as a reference. The error is zero at the beginning of the test, where the sensor has been calibrated, and reaches a maximum value of about 0.9%.

The average value of signal  $v_{DC}$  is shown at the bottom of the same figure. The voltage changes of about  $\Delta V_{DC} = 4$  mV confirming that the shaker slightly modifies the average position of its table. Since the sensitivity is known, it is thus possible to calculate the corresponding displacement, finding a value of about  $\Delta d = 15 \mu$ m. A variation of the working distance produces a variation in the sensitivity, as shown in Fig.3(b) and this accounts for the main contribution to

the acceleration error.

This test shows that, in these conditions, the sensor has a sensitivity that changes with a rate of about  $S_R = -600 \text{ ppm}/\mu\text{m}$ , result that has been confirmed through a theoretical analysis based on the optical model [15].

### B. High frequency vibration test

The same setup has been employed to test the sensor behavior at higher frequencies. At low frequency the sensor performance is limited by its nonlinear behavior and the stand resonances, whereas at high frequency the limitation comes from noise since the target displacements are dramatically reduced. This test has been performed using the setup of Fig. 5 and the vibrating table has been subjected to an average acceleration of about  $30 \text{ m/s}^2$  in a frequency range from 43 Hz to 3 kHz. The sensor has been calibrated at the beginning of the tests. From the measurement of the DC coupled signal an average target distance variation of about  $\Delta d = 20 \mu\text{m}$  has been estimated. This has allowed correcting the sensitivity of about 1.2% using the results obtained in the previous test.

The vibration amplitude is shown in Fig.7, which reports the distance obtained processing the acceleration measured with the accelerometer. Using bilogarithmic scales the two curves overlap and it is interesting to notice that at the highest frequency the measured displacement is of about 80 nm.

The acceleration obtained using the optical sensor is shown in Fig.8, where the output of the accelerometer is plotted together with the  $\pm 5\%$  accelerometer frequency flatness band. The figure shows a good agreement between the sensors both at low frequency, where the optical sensor has been calibrated, and at high frequency. The agreement is confirmed in Fig. 9 where the sensor

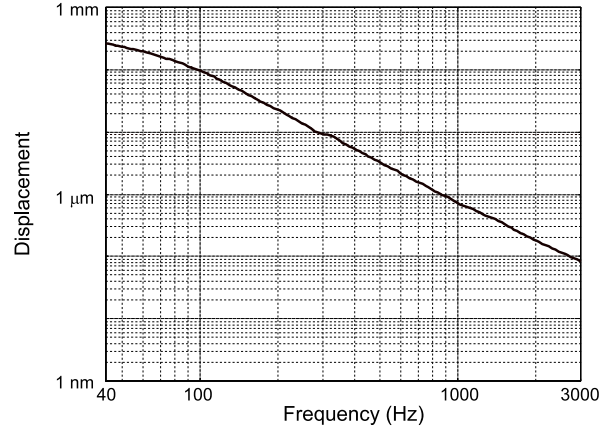

Fig. 7. Vibration amplitude as measured by the optical sensor and the amplitude obtained with the accelerometer (overlapped).

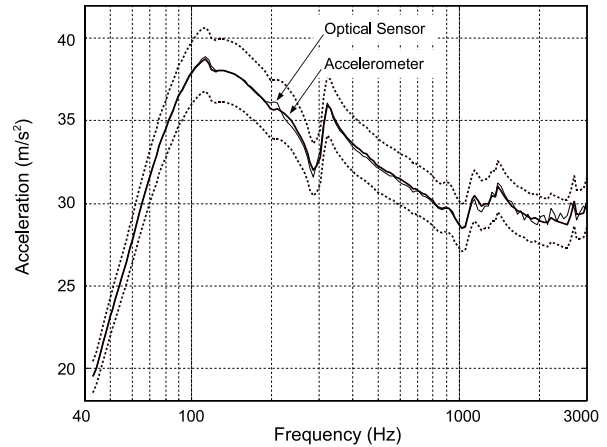

Fig. 8. Acceleration measured with the optical sensor and with accelerometer. The figure also shows the tolerance bands (dotted lines) due to the accelerometer specifications.

difference is shown. The maximum relative difference is of less than  $\pm 2\%$  in the full frequency range.

### C. Multi point sensor

The proposed technique has been employed to monitor the acceleration during a sinusoidal vibration test carried out on a PCB in order to highlight resonances and mounting defects. To this aim, the acceleration has been measured on the PCB surface using a multi-head sensor

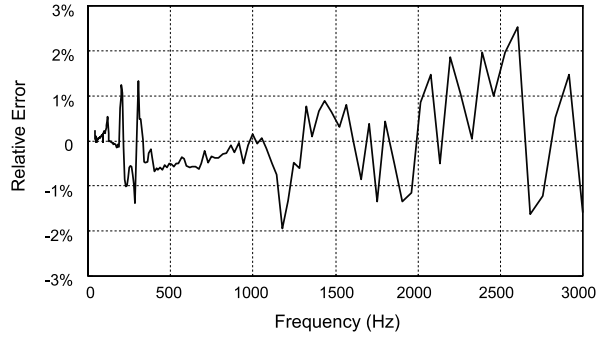

Fig. 9. Relative difference between the optical and piezoelectric sensor results.

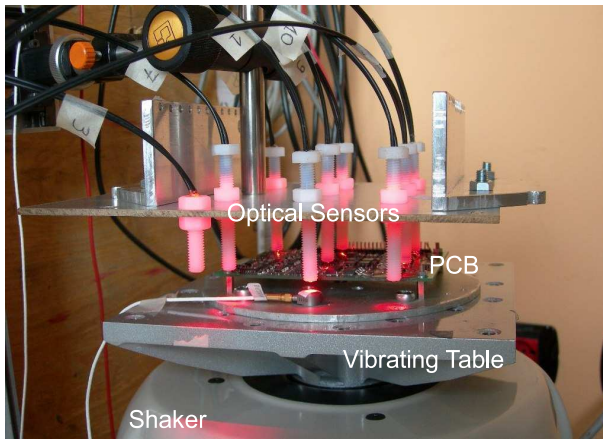

Fig. 10. A multi-head sensor composed of nine optical sensors.

composed of nine optical sensors arranged as shown in Fig.10. Two sensors are located at point TP1 and TP2 and for comparison purposes, a third optical sensor has been pointed on the accelerometer (TP3).

All the sensors have been calibrated contemporaneously driving the shaker with a sinusoidal signal at 33 Hz. The sensitivities of the sensors are of about  $1 \text{ mV}/\mu\text{m}$ , significantly lower than the value obtained in the previous tests both because of the different target reflectivity and of the higher sensor distance due to practical difficulties in facing the sensor head to the PCB.

The results for the three test points are summarized in Fig. 11. The curves for TP1 and TP2 show a first

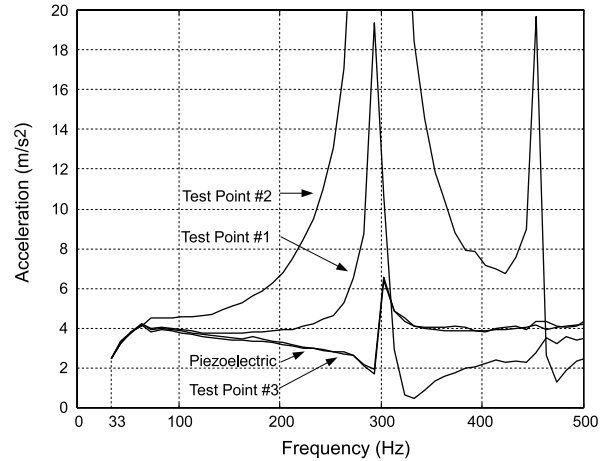

Fig. 11. Measurement results obtained during the vibration tests of a PCB. Test points TP1, TP2 are located on the PCB surface while TP3 is located on the accelerometer surface.

resonance at about 290 Hz and a second resonance at about 460 Hz. Moreover, they also highlight that the PCB is much more stressed at TP2, which is approximatively in the middle of the board, as expected.

Readings from the sensor at TP3 are in good agreement with those from the commercial accelerometer at any frequency demonstrating that the sensitivity does not change significantly during the test and that the parasitic vibrations on the sensor stand are negligible. The data from all the other sensors (represented by TP1 and TP2 in Fig.11) overlap up to about 70 Hz, confirming that the calibration frequency has been chosen correctly, well below the mechanical resonances.

## V. CONCLUSIONS

Displacement sensors based on plastic optical fibers are an interesting solution to measure, without contact, the acceleration of components subjected to vibration tests. These sensors have a low cost, in comparison with piezoelectric accelerometers, but they need being calibrated before each use in order to overcome the

effects caused by non-uniform targets. The proposed solution takes advantage of a reference accelerometer, which is typically employed to control the shaker, to easily calibrate the whole set of optical sensors contemporaneously employed to map vibration distributions. Calibration issues, like the choice of the suitable calibration frequency and the effects related to the changes of the sensor distance during the test, have been addressed. Experimental results have been carried out both using a single sensor facing a high reflectivity target and using a multi-head sensor monitoring non-cooperative targets.

#### REFERENCES

- [1] S. Donati, "Electro- optical instrumentation: sensing and measuring with lasers", *Upper Saddle River : Prentice Hall*, 2004.
- [2] A. Link, H. J. Von Martens, "Amplitude and phase measurement of sinusoidal vibration in the nanometer range using laser interferometry ", *Measurement 24, Elsevier*, pp. 55-67, 1998.
- [3] P. Castellini, M. Martarelli, E.P. Tomasini, "Laser Doppler Vibrometry: Development of advanced solutions answering to technology's needs", *Mech. Syst. Signal Process.*, vol. 20, no. 6, pp. 1265-1285, 2006.
- [4] A. Chijioko, J. Lawall, "Laser Doppler vibrometer employing active frequency feedback", *Appl. Opt.*, vol. 47, pp. 4952-4958, 2008.
- [5] G. Giuliani, M. Norgia, S. Donati, T. Bosch, "Laser diode self-mixing technique for sensing applications", *J. Opt. A: Pure Appl. Opt.*, vol. 4, pp. S283-S294, 2002.
- [6] G. Perrone, A. Vallan, "A Low-Cost Optical Sensor for Noncontact Vibration Measurements", *IEEE Trans. Instrum. Meas.*, vol. 58, no. 5, pp. 1650 - 1656, 2009.
- [7] F. Suganuma, A. Shimamoto, K. Tanaka, "Development of a differential optical - fiber displacement sensor", *Appl. Opt.*, vol. 38, no. 7, 1999.
- [8] H. Cao, Y. Chen, Z. Zhou, G. Zhang, "General models of optical fiber - bundle displacement sensors", *Microwave Opt. Tech. Lett.*, vol. 47, no. 5, 2005.
- [9] R. O. Cook, C. W. Hamm, "Fiber optic lever displacement transducer", *Appl. Opt.*, vol. 18, no. 19, pp. 3230-3241, 1979.
- [10] O. Ziemann, J. Krauser, P. E. Zamzow, and W. Daum, "POF Handbook, Optical Short Range Transmission Systems", *Springer, 2nd Edition*, 2008.
- [11] A. Shimamoto, K. Tanaka, "Optical fiber bundle displacement sensor using an ac-modulated light source with subnanometer resolution and low thermal drift", *Appl. Opt.*, vol. 34, no. 25, pp. 5854-5860, 1995.
- [12] R. Dib, Y. Alayli, P. Wagstaff, "A broadband amplitude-modulated fibre optic vibrometer with nanometric accuracy", *Measurement, Elsevier Science*, vol. 35, no. 2, pp. 211-219, 2004.
- [13] X. Li, K. Nakamura, S. Ueha, "Reflectivity and illuminating power compensation for optical fibre vibrometer", *Meas. Sci. Technol.*, vol. 15, no. 9, pp. 1773-1778, 2004.
- [14] M.L. Casalicchio, G. Perrone, A. Vallan, "A Fiber Optic Sensor for Displacement and Acceleration Measurements in Vibration Tests", *I2MTC 2009 - Proc. Int. Instr. Meas. Tech. Conf.*, Singapore 5-7th May 2009, pp. 1676-1680, 2009.
- [15] J.B. Faria, "A Theoretical Analysis of the Bifurcated Fibre Bundle Displacement Sensor", *IEEE Trans. Instrum. Meas.*, vol. 47, no. 3, pp. 742-747, 1998.
- [16] A. Suhadolnik, A. Babnik, J. Mozina, "Optical fiber reflection refractometer", *Sensor and Actuator B, Elsevier*, pp. 428-432, 1995.
- [17] A. Savitzky, M.J.E. Golay, "Smoothing and differentiation of data by simplified least squares procedures", *Anal. Chem.*, vol. 36, pp. 1627-1639, 1964.

PLACE  
PHOTO  
HERE

**Alberto Vallan** was born in Italy in 1967. He received the M.S. degree in Electronic Engineering in 1996 from Politecnico di Torino, Italy, and in 2000 the Ph.D. degree in Electronic Instrumentation from the University of Brescia, Italy. He is currently assistant professor with the Department of Electronics of Politecnico di Torino. His main research interests are digital signal processing and development and characterization of sensors and instruments for industrial applications.

PLACE  
PHOTO  
HERE

**Maria Luisa Casalicchio** was born in Italy in 1982. She received the M.S. degree in Electronic Engineering in 2007 from Politecnico di Torino, Italy. She is currently a Ph.D. student in Metrology at Politecnico di Torino, Italy. Her main fields of interest are the development and the metrological characterization

of acquisition systems and fiber optic sensors.

PLACE  
PHOTO  
HERE

**Guido Perrone** was born in Italy in 1965. He holds a Ph.D. in Electromagnetics from Politecnico di Torino (Italy), where he is currently with the Department of Electronics, lecturing on Optical Components and on Microwave Devices. His research activity is mainly in the fields of fiber optical sensors

and of high power fiber lasers. Dr. Perrone is member of IEEE/MTTS, of IEEE/Photonics Society and of the Optical Society of America.