

A vibration absorber for motorcycle handles

Original

A vibration absorber for motorcycle handles / Fasana, A., Giorcelli, E.. - In: MECCANICA. - ISSN 0025-6455. - STAMPA. - 45(1):(2010), pp. 79-88. [10.1007/s11012-009-9229-8]

Availability:

This version is available at: 11583/2280269 since:

Publisher:

Springer

Published

DOI:10.1007/s11012-009-9229-8

Terms of use:

This article is made available under terms and conditions as specified in the corresponding bibliographic description in the repository

Publisher copyright

(Article begins on next page)

A vibration absorber for motorcycle handles

Alessandro FASANA, Ermanno GIORCELLI

Politecnico di Torino

Dipartimento di Meccanica

Corso Duca degli Abruzzi, 24

I-10129 Torino – Italy

+39 011 0903397

+39 011 0906999

alessandro.fasana@polito.it, ermanno.giorcelli@polito.it

ABSTRACT

This paper describes the application of a vibration absorber to ameliorate the comfort of motorcycle handles. The concept of dynamical absorber is briefly summarised and a frequency response function is expressed as the ratio of vibration amplitudes (transmissibility). Some practical hints on the tuning strategy are also suggested in order to correctly define the absorber and then achieve the most effective vibration reduction. A specifically designed item is then presented, with the peculiar characteristic of taking advantage of the damping properties of viscoelastic material undergoing shear deformations. An experimental verification of the good performances of the absorber is eventually given on the basis of both a modal analysis of a motorbike and the testing of its handle on an electrodynamical shaker.

KEYWORDS

Vibration absorber, motorcycle handle, modal analysis, comfort.

INTRODUCTION

The exposure of men, or parts of their bodies, to vibration has been the subject of numerous studies for decades and has conducted to a better understanding of the many parameters governing the human response to vibrations. In particular, as regards the hand-arm system, vibration can cause changes in tendons, muscles, bones and joints, and can affect the nervous system to eventually produce the so-called Hand-Arm Vibration Syndrome (HAVS). Quantification of the parameters affecting the subjective response of different individuals has lead to define numerous standards as, for example, the EN ISO 5349-1 and EN ISO 5349-2 regarding the measurement and evaluation of human exposure to hand-transmitted vibrations. Standards focus mainly on the most remarkable effects of hand-held power tools, which can in fact affect the well being of workers, but of course give

no indication on how to quantify and increase the comfort of a motorcycle handle, which is the purpose of this paper. Some significant information can indeed be found in literature [1-7] leading, together with the indications of the standards, to the conclusion that the frequency range to be investigated extends approximately from 50 to 300 Hz. These frequencies not only are in the range felt by the hand and the fingers, but can well be excited by the various harmonics due to the unbalance of the engine.

The present work takes start from the observation that most of the motorcycles mount a couple of lumped masses fixed at the very end of their handles. The fixtures are various and sometimes show the presence of rubber elements but all seem to apply the basic idea that, given a certain force acting on the handle, a large mass will decrease the acceleration and therefore increase the comfort. There is indeed a second, possibly positive, effect of these masses: when the dynamic response of the handle is dominated by a single mode, they may shift the mode itself to a frequency range barely excited by the engine or felt by the hands. The aim of this work is to investigate the possibility of designing a vibration absorber tuned to the frequency of maximum discomfort for the biker.

2. THE VIBRATION ABSORBER

In this section a brief explanation on the dynamics of the vibration absorber is given within the limits of the linear theory albeit it is well known that non-linear effects are not always negligible [8]. In Fig. 1 the typical vibration absorber is sketched.

In this model the set formed by mass m_1 , spring k_1 and damper c_1 represents the vibration mode of the bike handle whose amplitude is to be reduced, and the set formed by mass m_2 , spring k_2 and damper c_2 is properly the vibration absorber.

Under the hypothesis that the motion of the base is $y(t) = y_0 e^{i\Omega t}$, the steady state responses of the two masses are harmonic functions too in the form $x_1(t) = A e^{i\Omega t}$ and $x_2(t) = B e^{i\Omega t}$ where A and B are complex constants. The equations of motion of the two masses are:

$$\begin{bmatrix} k_1 + k_2 - m_1 \Omega^2 + i\Omega(c_1 + c_2) & -k_2 - i\Omega c_2 \\ -k_2 - i\Omega c_2 & k_2 - m_2 \Omega^2 + i\Omega c_2 \end{bmatrix} \begin{Bmatrix} A \\ B \end{Bmatrix} = \begin{Bmatrix} f_0 \\ 0 \end{Bmatrix}$$

with $i = \sqrt{-1}$ and $f_0 = k_1 y_0 + i \Omega c_1 y_0$.

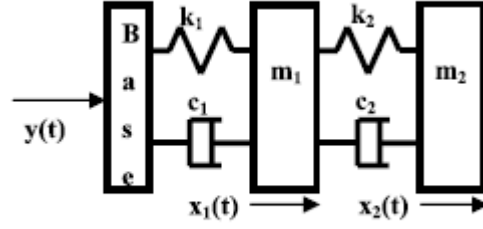

Fig. 1 Model of the dynamic absorber

The presence of the damping, which is of great benefit in practical applications, is here masking the effect of the dynamic absorber on the motion of the masses but, with $c_1=c_2=0$, it is straightforward to write

$$A = \frac{\omega_1^2(\omega_2^2 - \Omega^2)}{\Delta} y_0 \quad B = \frac{m_1}{m_2} \frac{\omega_1^2 \omega_2^2}{\Delta} y_0$$

with $\Delta = \Omega^4 - \Omega^2(\omega_1^2 + \omega_2^2 + \omega_2^2 m_2/m_1) + \omega_1^2 \omega_2^2$, $\omega_1^2 = k_1/m_1$ and $\omega_2^2 = k_2/m_2$.

The denominator reveals, of course, the presence of two resonances whilst the numerators demonstrate the possibility of bringing to zero the amplitude of vibration A of mass m_1 , i.e. the handle of the bike in this model, with a corresponding limited amplitude B of the second mass.

It is interesting to note that both A and B are influenced by the ratio of the masses but in a form not simple to study, especially if the effects of damping are to be included. A detailed discussion of the effects of c_2 , under the hypothesis $c_1 = 0$, is presented in the classical text by Den Hartog [9] and more recently in [10]. An indication of these combined effects can be given by the curves in Fig. 2 showing the consequences of varying mass m_2 on the Frequency Response Functions (FRFs) A/y_0 and B/y_0 , with constant damping ratios $\zeta_1 = c_1/(2\sqrt{k_1 m_1}) = 0.02$, $\zeta_2 = c_2/(2\sqrt{k_2 m_2}) = 0.05$ and $\omega_1 \equiv \omega_2$.

The curves in Fig. 2 (all of them calculated in order to have $\omega_1 = \omega_2$) indicate that a positive effect of increasing the mass m_2 is the reduction of both the A and B amplitudes around ω_1 . On the contrary negative features are given by the rise of the response of the first mode and the large values achieved by B , especially evident with small masses and possibly causing harmful effects on the fatigue life of the component.

3. DESIGN OF THE ABSORBER

The absorber, whose principal features have been so far described, has to be designed to fit on an actual handle. The starting point is the knowledge of the resonance frequency of interest ω_1 which is usually associated to the first bending mode of the handle and can be measured with good accuracy. For a sport motorcycle the handle itself can be modelled as a clamped-free straight beam whose characteristic properties are the length L_1 , the area moment of inertia of the cross-section I_1 and the material elastic modulus E_1 .

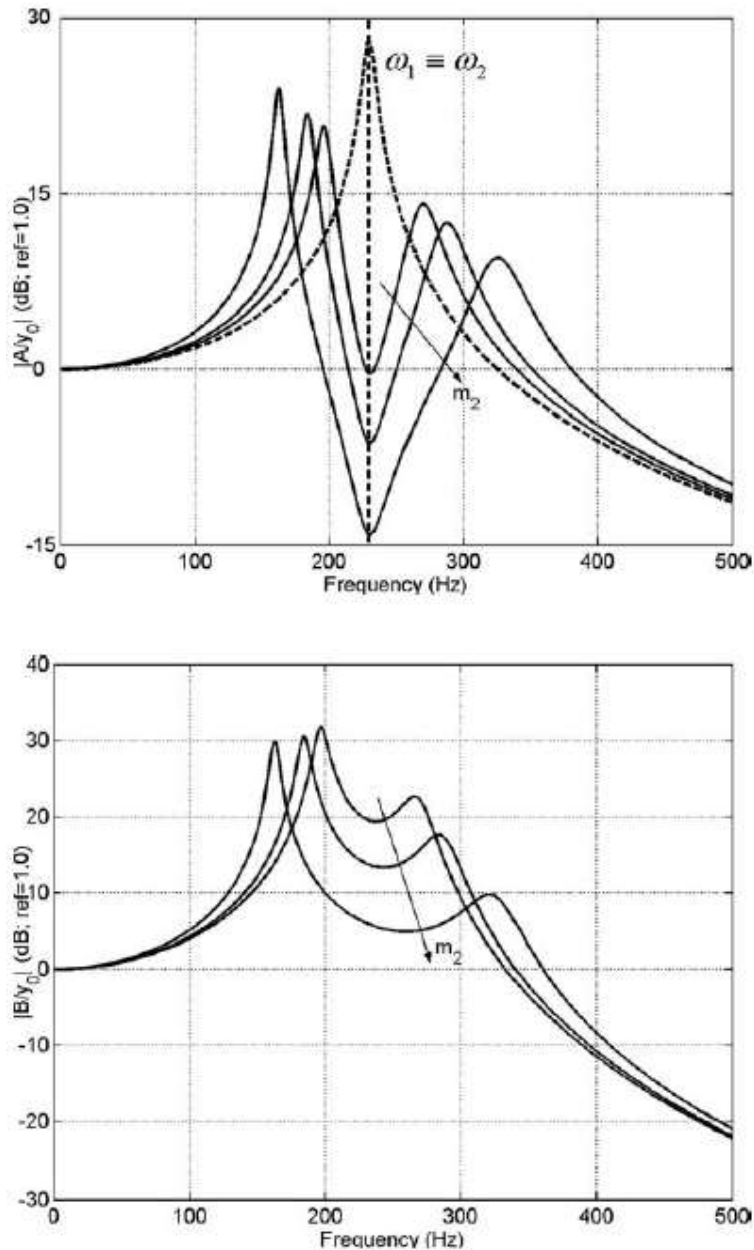

Fig. 2 Transmissibilities of the dynamic absorber with m_2 increasing. (a) Solid lines: A/y_0 ; dashed line: FRF of the original sdf system; (b) B/y_0 ; $k_1 = 1.26 \times 10^5$ N/m, $m_1 = 0.06$ kg, $\omega_2 = 230$ 2π rad/s, $m_2/m_1 = 1/10, 1/5, 1/2$

According to the most common configuration of hollow circle section, the flexural stiffness k_1 of such a beam is:

$$k_1 = \frac{3E_1}{L_1^3} \frac{\pi}{4} (R_E^4 - R_I^4)$$

with R_E , R_I respectively indicating the external and internal radii of the beam. Of course it is not always possible to rely on a model as simple as the clamped-free straight beam to simulate the behaviour of an actual handle. For example in off-road motor cycles the handlebar is usually bent and connected to the front fork by means of silent blocks. Anyway, given any particular handle, the geometric and material parameters are all fixed and may yield the stiffness k_1 , possibly by a finite elements model.

With ω_1^2 and k_1 , the equivalent mass m_1 is quickly computed thus allowing for the definition of the damping coefficient c_1 , given the damping factor ζ_1 . The damping factor, which is usually of the order of some percent, has of course to be extracted from the response function of the handle, either in the frequency or in the time domain, by any of the numerous possible techniques [11]. In this particular case the authors have implemented a frequency domain least squares fitting of the autospectra of the accelerations, based on a single degree of freedom model with viscous damping.

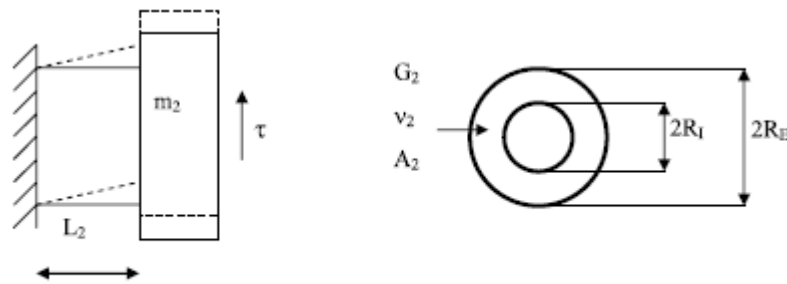

Fig. 3 Sketch of the vibration absorber and its shear deformation mechanism

The mode shape revealing large displacements of the handles is in fact well separated in frequency and can safely be assumed to be scarcely influenced by other resonances.

The second stiffness is determined on the basis of the sketch of Fig. 3.

The material, with elastic modulus E_2 and shear modulus G_2 , can be thought to be of rubber or viscoelastic type and is supposed to undergo shear deformations so that its stiffness is:

$$k_2 = \chi \frac{G_2 A_2}{L_2}$$

The shear coefficient χ , written for an hollow circle, is

$$\chi = \frac{(7 + 6\nu)(1 + m^2)^2 + (20 + 12\nu)m^2}{6(1 + \nu)(1 + m^2)^2}$$

where ν is the Poisson's ratio and $m = R_I/R_E$.

When designing this component it is important to keep its length L_2 as short as possible in order to avoid its bending. This would cause two main effects: the first is that the dynamic absorber would not be tuned to the desired frequency because of the replacement of the shear by the bending stiffness. The second is that the resulting damping would be smaller and would limit the performance of the absorber in the frequency bands around the two resonances. This fact can be better understood if one takes into consideration the two typical layouts in which a viscoelastic material is usually arranged, the free and the constrained layer [12, 13]. In the free layer configuration the material undergoes flexural deformations whilst in the constrained configuration shear deformations are predominant and, given the same quantity of material, give rise to a larger damping effect.

On the other hand if L_2 is too short the resulting stiffness k_2 can reach very high values: this fact can make the tuning of the absorber a difficult task because mass m_2 is determined with the ratio $m_2 = k_2/\omega_2^2$. It must in fact be stressed that mass m_2 depends on its volume and can not be chosen arbitrarily: for a fixed external radius, large masses would require long lengths and this would increase the possibility of having bending vibrations instead of the desired shear behaviour. The final choice of the dimensions and the material must therefore be a compromise of opposite requirements and the curves in Fig. 4 can be of help, showing how the bending stiffness approaches the shear value.

The longitudinal behaviour of the component has not been taken into consideration in view of our particular application. The handle is in fact so stiff along its axis that the acceleration in this direction has negligible entity and does not need any further attenuation.

The damping coefficient c_2 depends on the nature of the material and, for a typical viscoelastic rubber, can be supposed to give a damping factor ζ_2 of (at

least) some percent points.

The absorber so far described has been assembled by using both home made and standard elements according to the sketch of Fig. 5. The elastic element k_2 is a standard anti-vibration mount made from a couple of screws bonded to a compounded natural rubber disk and can simply be retrieved on many commercial catalogues. On the left side it is screwed to m_3 , which is in turn screwed to the handle and constitutes the interface between the absorber and the motorcycle; on its right side k_2 is fixed to a steel cylinder which constitutes mass m_2 . Both k_2 and m_2 can simply be dismantled and modified in order to correctly tuning the system at the desired frequency.

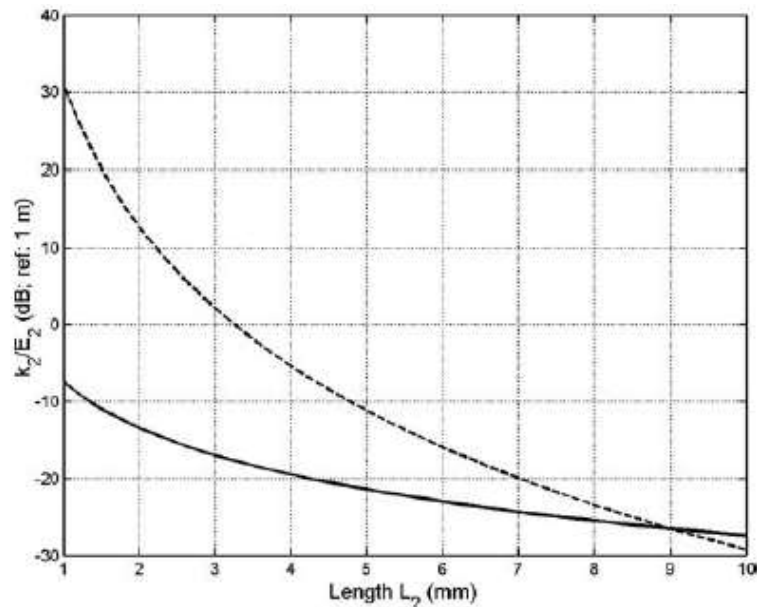

Fig. 4 Shear (solid line) and bending (dashed line) stiffness of the absorber with $m = R_I/R_E = 0$

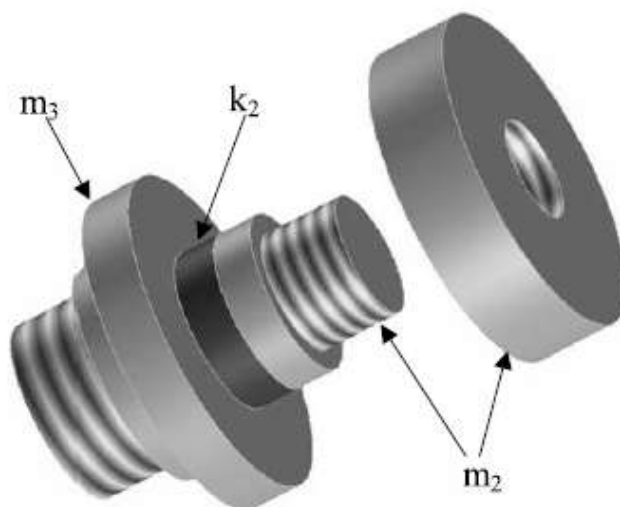

Fig. 5 The proposed configuration of the absorber (k_2, m_2) with its interface (m_3) to the handle

4. EXPERIMENTAL TEST

To verify the performances of the assembly some tests have been conducted at first on an actual motorcycle and then on its right handle. A four-cylinder sport motorcycle was installed on a rolling road and various run-ups from 2000 to 12500 rpm were executed in its 6th gear. The rate of the engine speed ramp of the engine was not controlled but the rider was able to repeat the same run-up with good accuracy just after a few trials. The system was instrumented with 21 triaxial accelerometers and a simultaneous sampling of all the channel were performed to allow for a modal analysis. The time-frequency representation of the acceleration data (cascade diagram) clearly indicates that some modes of the structure are well excited by the first and/or second order unbalance of the engine, depending on their frequency range.

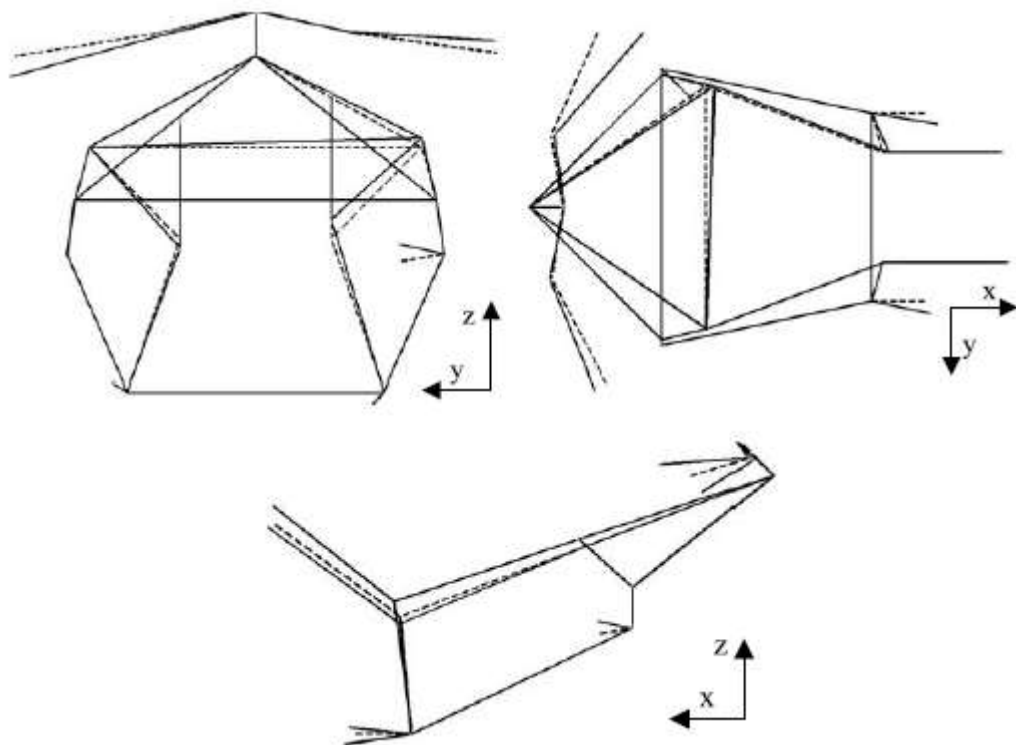

Fig. 6 The experimental mode shape at about 100 Hz of the motorcycle; the *dashed lines* represent the undeformed structure

It was not possible to directly measure the excitation forces produced by the engine so that an output-only modal analysis was performed in the frequency domain by two distinct methods, namely the RFPz [14] and the peak amplitude [11]. The results of this investigation reveals, among the others, the presence of a mode at about 100 Hz (Fig. 6) with large displacements of the handles. It may be

of interest to remark that this frequency can be excited by both the 1st and 2nd order unbalance at 6000 rpm and 3000 rpm respectively.

A second mode involving the handlebar is at about 140 Hz but is not considered in this discussion because it gives rise to much smaller accelerations and displacements and is not to be considered cause of such a great annoyance as the previous one.

The right handle was soon after removed from the motorcycle and rigidly mounted on the moving table of an electrodynamical shaker (Fig. 7) transmitting in the vertical (z) direction a flat spectrum excitation in the band from 50 to 400 Hz with a sine sweep in four minutes. This tests confirmed the results of the modal analysis with a resonance at about 100 Hz (Fig. 8, solid line) of the FRF between point 4 and point 1 (transmissibility).

The same handle without its standard end mass (point 5, Fig. 7), which is normally fixed by a rigid rubber element and weights almost 200 g, has a resonance at about 240 Hz (Fig. 8, dashed line). As expected the contribution of this component is characterised by an inertial effect: the frequency moves from 240 Hz to 100 Hz and the resonant peak becomes sharper and higher. In fact, given the same stiffness k and damping c of the structure, the damping ratio ζ , which governs the shape of the FRF, decreases with mass increasing.

The physical assembly of the absorber drawn in Fig. 5 was eventually mounted on the handle: in Fig. 9 the arrow indicates the rubber element acting as stiffness k_2 , with m_3 and m_2 clearly visible (also the accelerometer contributes to mass m_2 for a total of about 55 grams). The FRF of the handle is plotted in Fig. 10 in three configurations: no mass (dashed line), with mass m_3 (dotted line) and with the vibration absorber (solid line and crosses). The frequency of interest is now at about 170 Hz, i.e. at the resonant frequency of the handle with fixture m_3 (dotted line), and even when the absorber is not correctly tuned (solid line with its minimum at 200 Hz) the frequency response of the handle is lower than the original one (dashed line). When the tuning is forced at about 170 Hz by simply adding some grams to m_2 , the maximum vibration amplitude still decreases and is reached at about 115 Hz, not far from the resonance of the handle with its original mass (Fig. 8, solid line) but with a much lower amplitude.

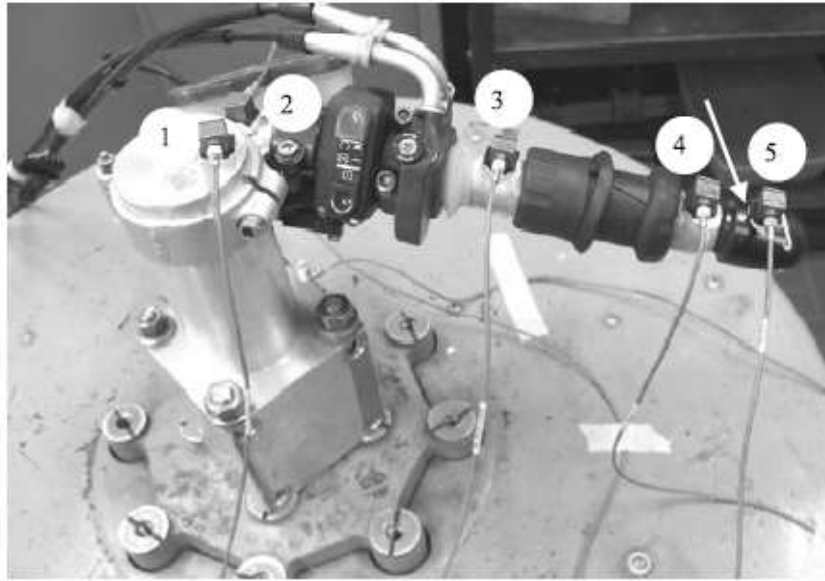

Fig. 7 The handle fixed to the electrodynamic shaker. The original mass is indicated by the *arrow*

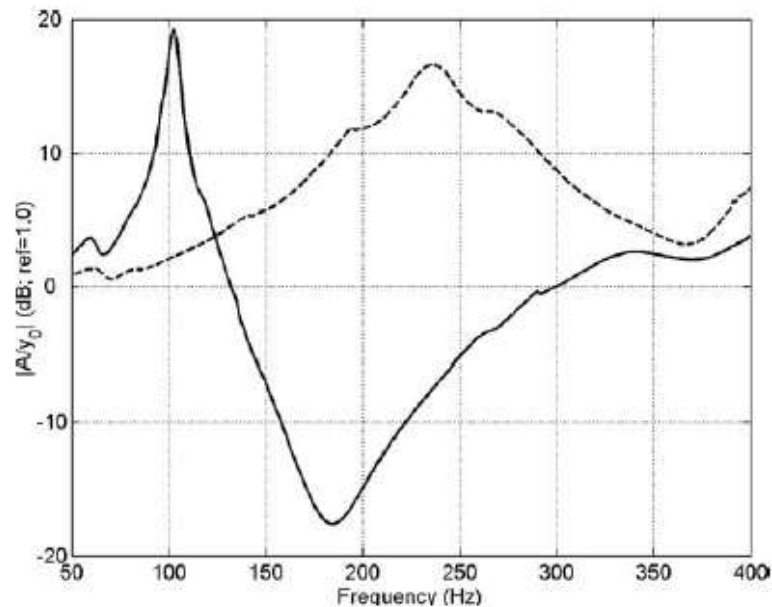

Fig. 8 Experimental FRFs of the handle with (*solid line*) and without (*dashed line*) its standard mass

Also the presence of second mode of vibration at about 250 Hz is not a major drawback, especially when considering its very low amplitude.

5. COMMENTS

From the previous section it may be remarked that the presence of the absorber is positive also when its tuning is not accurate and this fact is confirmed also by the numerical results in Fig. 11. Even when k_2 varies from 0.67 to 1.5 times its ideal value $m_2\omega_1^2$, thus changing the tuning of the system, the vibration amplitudes of

mass m_1 are lower than the original one (dashed line). These curves even show that in order to keep both the resulting resonant peaks limited to low values it is better not to tune the absorber on frequency ω_1 but to choose a lower ω_2 .



Fig. 9 The handle with the proposed vibration absorber

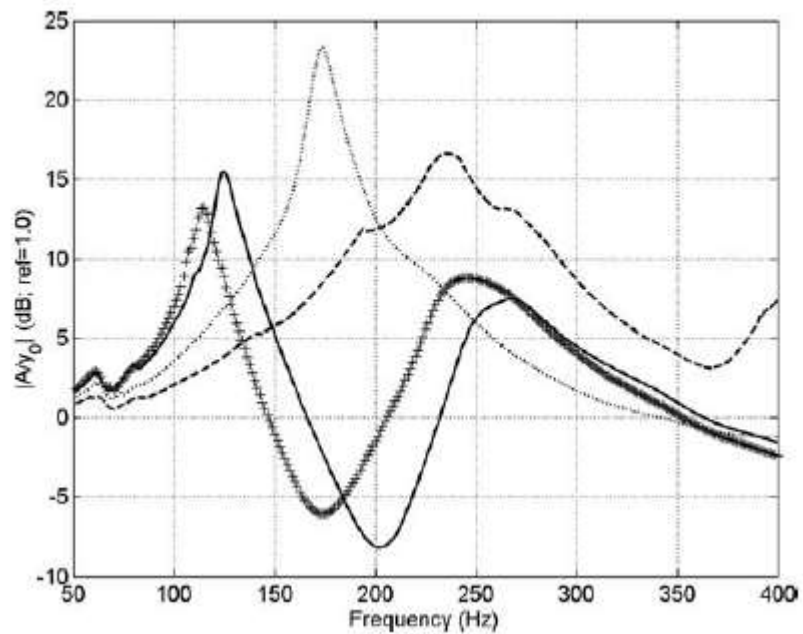

Fig. 10 Experimental response of the handle with or without the absorber. *Dashed line*: handle; *dotted line*: handle with fixture; *solid line*: handle with absorber; *crosses*: tuned absorber

Fig. 11 also gives important information on the effectiveness of the proposed solution at various temperatures. Although the elastic modulus of rubber type materials decreases with temperature, its variation is usually not so remarkable to

lead to a complete mistuning of the absorber. To confirm this assertion the absorber alone has been tested in an environmental chamber and in fact its resonant frequency ω_2 varied less than 10% in the temperature range 0-30 °C.

The limited sensitivity of the absorber to mistuning is encouraging also in view of the fact that the right and left handles can not be perfectly equal: their slightly different resonances can nonetheless be largely limited by the same combination of m_2 , k_2 and c_2 .

Finally Fig. 12 displays the valuable effects of increasing the damping factor ζ_2 from 2% to 5% to 10%. Damping, as expected, gives great benefits but even in the worst and not very realistic case ($\zeta_2=2\%$) a loss of about 4 dB is achieved.

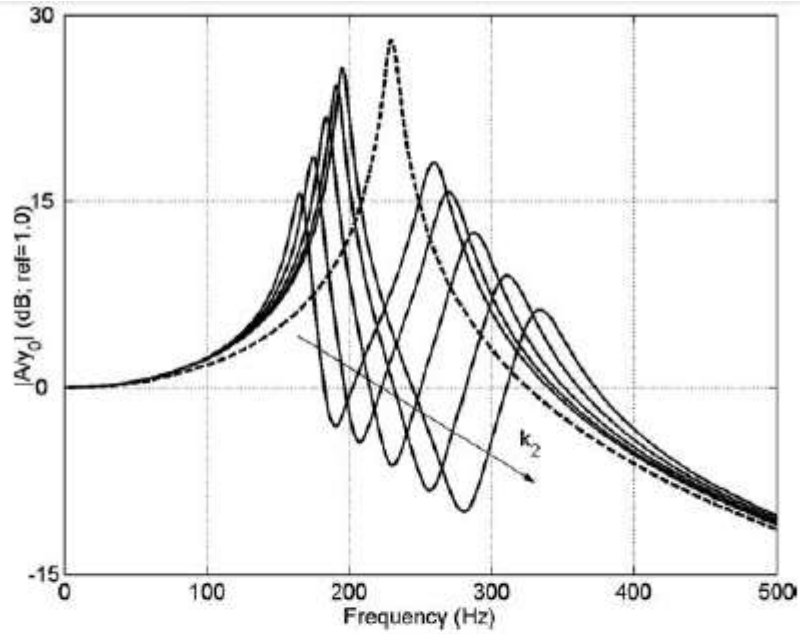

Fig. 11 Numerical FRFs with various levels of mistuning ($k_2/(m_2\omega_1^2) = 0.67, 0.80, 1.00, 1.25, 1.5$)

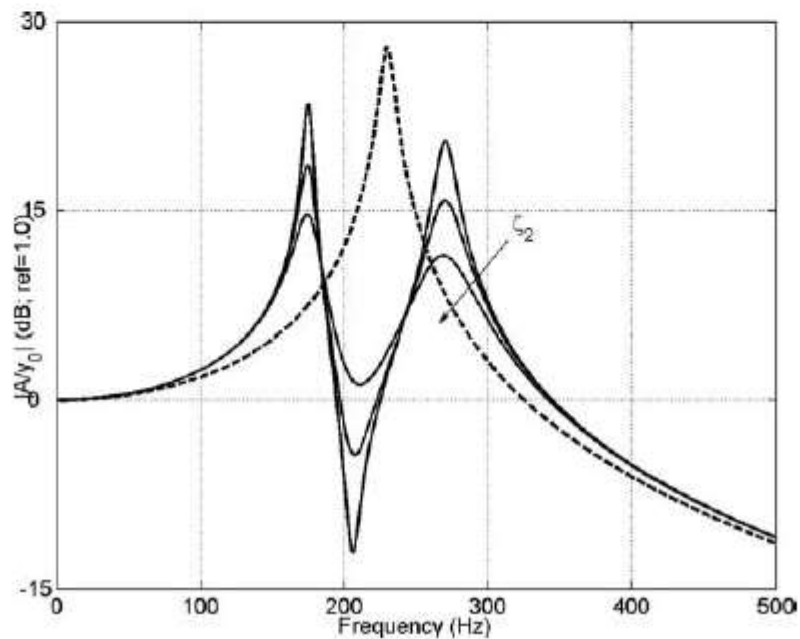

Fig. 12 Numerical FRFs with increasing levels of damping ($\zeta_2 = 2\%, 5\%, 10\%$)

The curves in figures 11 and 12 have been drawn with $\zeta_1 = 2\%$ but show a similar behaviour (with lower amplitude values) also when the damping is larger, which is the case for example of the mode at 240 Hz in Fig. 8.

It is essential to stress that the whole discussion presented this paper is based on the assumption that a single mode has to be limited in amplitude so that the application of a vibration absorber can be a convenient choice. But any absorber is effective only on a single resonance so that a modal analysis of the structure has to be performed with the aim of selecting the mode shape generating the most

annoying disturbance for hands and arms.

6. CONCLUSIONS

This work discusses the application of the concept of vibration absorber to motorcycle handles. Some aspects of the system behaviour are theoretically dealt with and evidence is given on the influence of damping, added mass and mistuning. The guidelines for designing an absorber based on the shear deformation of a (visco)elastic material has been presented and its features discussed. A practical, although primitive, realisation of such a device as been tested under controlled laboratory conditions and proved effective and simple to tune at the desired frequency. It may be worth to point out that the description of the system performances is based on the reduction of the vibration amplitude of a single resonance so that a preliminary modal analysis is important to visualize the mode shapes of the system. Future work should be devoted to predict the fatigue life of the rubber element (spring) of the absorber and to perform road tests in order to verify the benefits on handle comfort in real life conditions.

REFERENCES

- 1) Griffin M J (1990) Handbook of human vibration. Academic Press, London
- 2) Cossalter V, Doria A (2000) Riders sensitivity to motorcycle vibration. 2nd International conference on whole-body vibration injuries, Siena, Italy
- 3) Cossalter V, Doria A, Fabris D, Maso M (2006) Measurement and identification of the vibration characteristics of motorcycle riders. ISMA 2006, Leuven, Belgium: 1793-1806
- 4) Tominaga Y (1995) Low intensity vibration exposure in postmen. 9th Cent Eur J Public Health, 3 Suppl: 118-9
- 5) Mirbod S M, Yoshida H, Jamali M, Masamura K, Inaba R, Iwata (1997) Assessment of hand-arm vibration exposure among traffic police motorcyclists. Int Arch Occup Environ Health 70(1): 22-28
- 6) Rossi G L, Tomasini E P (1995) Hand-arm vibration measurement by a laser scanning micrometer. Measurement, Volume 16, Number 2: 113-124
- 7) Anttonen H, Virokannas H, Niskanen J (1995) Hand-arm vibration and terrain vehicles. Cent Eur J Public Health, 3 Suppl: pp. 123-125
- 8) Mikhlin Y V, Reshetnikova S N (2005) Dynamical interaction of an elastic system and essentially nonlinear absorber. J Sound Vibr 283: 91–120
- 9) Den Hartog J P (1947) Mechanical vibrations. McGraw-Hill, New York
- 10) Liu K, Liu J (2005) The damped dynamic vibration absorber: revisited and new results. J Sound Vibr 284: 1181-1189

- 11) Maia N M M, Silva J M M (1997) Theoretical and experimental modal analysis. Taunton Research Studies press, New York
- 12) Garibaldi L., Onah H N (1996) Viscoelastic material damping technology. Becchis Osiride, Torino
- 13) Nashif A D, Jones D I G, Henderson J P (1985) Vibration damping. Wiley, New York
- 14) Fasana A (2009), Modal parameters estimation in the Z-domain. Mechanical Systems and Signal Processing 23: 217-225