

Estimation of M-wave scale factor during sustained contractions at high stimulation rate

*Original*

Estimation of M-wave scale factor during sustained contractions at high stimulation rate / Mesin, L., Farina, D.. - In: IEEE TRANSACTIONS ON BIOMEDICAL ENGINEERING. - ISSN 0018-9294. - STAMPA. - 52:5(2005), pp. 869-877. [10.1109/TBME.2005.845227]

*Availability:*

This version is available at: 11583/1913070 since:

*Publisher:*

IEEE

*Published*

DOI:10.1109/TBME.2005.845227

*Terms of use:*

This article is made available under terms and conditions as specified in the corresponding bibliographic description in the repository

*Publisher copyright*

(Article begins on next page)

**ESTIMATION OF M-WAVE SCALE FACTOR DURING SUSTAINED  
CONTRACTIONS AT HIGH STIMULATION RATE**

**Luca Mesin<sup>1</sup> and Dario Farina<sup>2,\*</sup>**

<sup>1</sup>*Laboratorio di Ingegneria del Sistema Neuromuscolare, Dip. di Elettronica, Politecnico di Torino,  
10129 Torino, Italy*

<sup>2</sup>*Center for Sensory-Motor Interaction, Aalborg University, Aalborg, Denmark*

**Keywords:** electromyography, electrically elicited contractions, fatigue, scale factor

**Running title:** Estimation of M-wave widening

**Corresponding author:**

\* Dario Farina, Ph.D.

Center for Sensory-Motor Interaction

Aalborg University

Fredrik Bajers Vej 7 D-3, DK-9220 Aalborg, Denmark

tel: +4596358821; fax: +4598154008

e-mail: [df@hst.aau.dk](mailto:df@hst.aau.dk)

© 2005 IEEE. Personal use of this material is permitted. Permission from IEEE must be obtained for all other uses, in any current or future media, including reprinting/republishing this material for advertising or promotional purposes, creating new collective works, for resale or redistribution to servers or lists, or reuse of any copyrighted component of this work in other works

## **ABSTRACT**

In this study we propose a time-domain index to assess M-wave widening during high-frequency stimulation, as an objective parameter for quantifying muscle fatigue. At high stimulation frequencies, signal truncation, due to the delivery of the electrical stimulus before the M-wave generated by the previous stimulus extinguishes, biases the spectral frequency variables usually computed to estimate M-wave widening. Thus, we propose an estimator of the scale factor between two truncated M-waves. The estimator is derived from the Scale Transforms of the two signals, with an efficient implementation that avoids limits of resolution. The method was tested on both simulated and experimental signals. The simulations showed that the proposed technique is significantly less affected by signal truncation than previous approaches. The experimental recordings were collected from 11 subjects at stimulation frequencies of 20 Hz, 40 Hz, and 60 Hz. The scale factor estimation assessed M-wave widening in the three conditions, differentiating between the different rates of change of signal widening. The method proved to be significantly superior to M-wave spectral analysis. The technique can be applied to investigate myoelectric manifestations of muscle fatigue at stimulation rates that could not be analyzed in the past and thus opens new perspectives in the evaluation of electrical stimulation for training and rehabilitation protocols.

## INTRODUCTION

Transcutaneous electrical stimulation determines artificial activation of axon branches and depolarization of the innervated muscle fibers. When the current or voltage stimulus is provided, the motor units that are activated generate synchronous action potentials detectable at the skin surface. The potentials sum to form a compound signal, termed M-wave. The M-wave can be analyzed in the time or frequency domain [1] and provides information on the peripheral properties of the neuromuscular system [2][3] and on their changes due to fatigue [4], pathology [5], or exercise [6]. When the muscle is repetitively stimulated, the detected motor unit action potentials change their characteristics, reflecting the underlying physiological mechanisms. The physiological modifications in the muscle fiber membrane properties, such as the changes in intra-cellular action potential shape and conduction velocity, determines the M-wave widening over time [1][7]. This phenomenon can be analyzed to assess the so-called myoelectric manifestations of muscle fatigue [1].

The M-wave widening can be monitored by spectral analysis. An increase in signal duration corresponds to a reduction in signal bandwidth. Thus, characteristic spectral frequencies, such as mean or median frequencies, can be used as indicators of spectral compression and of expansion of the M-wave temporal support [8].

Indexes alternative to spectral variables have been proposed to describe the M-wave widening. LoConte et al. [9][10] expanded the M-wave by a series of Hermite-Rodriguez functions with varying scale factor (i.e., the multiplicative constant scaling the independent variable of a mathematical function). Olmo et al. [11] proposed the use of a single waveform to approximate the M-wave; the scale factor to be applied to the waveform to best approximate the original signal was used as an index of signal duration. More recently, Muhammad et al. [12] proposed a method for scale factor estimation, based on the time-domain analysis of the M-wave.

One of the problems encountered in the analysis of M-wave scale factor is the truncation of the signal that may occur at stimulation frequencies higher than the inverse of M-wave duration. Let's

consider, e.g., a semi-fiber length of 60 mm, average conduction velocity of 4 m/s, and a length of 15 mm of the intracellular action potential; the time needed for the action potentials to generate, travel along the fiber length, and extinguish is in this case 18.75 ms. Thus, stimuli repeated in time at a frequency higher than approximately 50 Hz will generate an M-wave before the previous one has extinguished at the tendons. The scatter of the neuromuscular junctions and of the conduction velocities of different motor units would lower this limit if the M-wave is considered instead of the single fiber potential. Moreover, if the conduction velocity decreases and the intra-cellular action potential widens, due to fatigue, the time needed for the extinction of the M-wave will be longer. When stimulating at high frequencies, the changes of the M-wave due to fatigue may be relatively fast over time. Thus, it is likely that the detected M-waves will be truncated by the successive stimulus and this truncation will be more and more important as fatigue develops.

The M-wave truncation introduces high frequency components, which bias the spectral based fatigue indexes. The time-domain based approaches proved to be less sensitive to this phenomenon [9][10][12]. However, there are no methods that allow reliable assessment of M-wave widening at stimulation rates higher than 30-35 Hz, without a significant bias introduced by signal truncation [12].

Although not reached during voluntary contractions, high stimulation rates may be used for training [13], functional exercise, or muscle characterization, such as in the case of countermeasures for reducing microgravity effects [14][15]. The analysis of the changes in membrane fiber properties at these stimulation rates is of importance both from the basic physiological point of view [16] and for the analysis of muscle fatigue properties, necessary for the design of training stimulation protocols [13].

The aim of this work was to propose a time-domain index to quantify M-wave widening during high-frequency stimulation, to quantify muscle fatigue. This index is the scale factor between two signals of equal or similar shape, detected in a time interval shorter than the signal duration. The method proposed for the estimation of the scale factor is based on the Scale Transform [17] and is

almost insensitive to signal truncation, thus applicable to M-waves elicited at high stimulation frequencies. The technique was applied to both simulated and experimental signals.

## METHODS

Two M-waves detected at different instants of time during a sustained electrically elicited contraction can be ideally described as:

$$\begin{aligned} x_1(t) &= s(t) \\ x_2(t) &= s(\alpha_0 t) \end{aligned} \quad t \in [0, T] \quad (1)$$

where  $\alpha_0$  is the scale factor between the two signals and  $T$  is the interval of observation (time interval between two subsequent stimuli). We will assume  $\alpha_0 < 1$ . With this notation, considering the signal  $s(t)$  to have bounded temporal support (here defined as the interval of time outside which  $s(t) = 0$ ), the temporal support of  $x_1(t)$  is  $\alpha_0$  times shorter than that of  $x_2(t)$ . The signals  $x_1(t)$  and  $x_2(t)$  have the same shape (with different scale factor) only if  $T$  is longer than the temporal support of  $x_2(t)$ . On the contrary, if  $x_2(t)$  has a longer duration than  $T$ , the two signals no longer have the same shape and, in principle, it is not possible to define a scale factor between them. Fig. 1 reports an example of M-wave detected during a sustained contraction at high stimulation rate. The first detected M-wave and the last one can be approximated by the signal model (1). The effect of signal widening as well as of signal truncation is evident.

**Figure 1 about here**

Let's consider the signal  $\tilde{x}_1(t, \alpha)$ , derived from  $x_1(t)$ :

$$\tilde{x}_1(t, \alpha) = \begin{cases} x_1(t) & t \in [0, \alpha T] \\ 0 & t \in ]\alpha T, T] \end{cases} \quad (2)$$

where  $\alpha < 1$ . The signal  $\tilde{x}_1(t, \alpha)$  is the truncated version of  $x_1(t)$ . The signals  $\tilde{x}_1(t, \alpha)$  and  $x_2(t)$  have the same shape if  $\alpha = \alpha_0$ . If the duration of  $x_1(t)$  is shorter than  $\alpha_0 T$ ,  $\tilde{x}_1(t, \alpha_0) = x_1(t)$  and  $x_2(t)$  is not truncated. In general,  $\tilde{x}_1(t, \alpha_0) \neq x_1(t)$  and  $x_2(t) = \tilde{x}_1(\alpha_0 t, \alpha_0)$ . Since the signals  $\tilde{x}_1(\alpha_0 t, \alpha_0)$  and  $x_2(t)$  have the same shape, the scale factor between them can be estimated without bias.

A further generalization concerns the possibility of limiting the time interval in which the signals are analyzed, skipping the first samples. For example, we may want to avoid the stimulation artifact and thus remove from the analysis the first acquired samples. In this case, the reference truncated signal will be:

$$\hat{x}_1(t, \alpha) = \begin{cases} x_1(t) & t \in [d, \alpha T] \\ 0 & t \in [0, d[ \cup ]\alpha T, T] \end{cases} \quad (3)$$

with  $d$  the duration of the time interval at the beginning of the recording which is not included in the scale factor estimation.

In order to obtain signals with the same shape, we should also define:

$$\hat{x}_2(t, \alpha) = \begin{cases} x_2(t) & t \in [d/\alpha, T] \\ 0 & t \in [0, d/\alpha[ \end{cases} \quad (4)$$

Fig. 2 shows these concepts for elementary signals. With the definitions of Eqs. (3) and (4), we obtain  $\hat{x}_1(\alpha_0 t, \alpha_0) = \hat{x}_2(t, \alpha_0)$  (Figure 2). From  $\hat{x}_1(t, \alpha_0)$  and  $\hat{x}_2(t, \alpha_0)$ , it is possible to estimate the scale factor between the two signals independently on the time interval of observation  $T$  and on the interval duration  $d$ . These two signals are indeed exactly the scaled version of each other for any choice of the parameters  $T$  and  $d$ . However, since  $\alpha_0$  is not known (it is indeed the unknown scale factor to be estimated), the signals  $\hat{x}_1(t, \alpha_0)$  and  $\hat{x}_2(t, \alpha_0)$  are not available. Rather, we may determine a set of signals  $\hat{x}_1(t, \alpha)$  and  $\hat{x}_2(t, \alpha)$  for any choice of  $\alpha$ . In the following we will propose a criterion to estimate  $\alpha_0$  from  $\hat{x}_1(t, \alpha)$  and  $\hat{x}_2(t, \alpha)$ .

**Figure 2 about here**

### A. Scale Transform

The Scale Transform (ST) of a signal  $v(t)$ , as firstly introduced by Cohen [17], is defined as:

$$D(c) = \frac{1}{\sqrt{2\pi}} \int_0^{+\infty} v(t) \frac{e^{-jc \ln t}}{\sqrt{t}} dt \quad (5)$$

where  $c$  is the scale variable. The ST of the signal  $v(\alpha t)$ , which is the scaled version of  $v(t)$ , is

$\frac{e^{jc \ln \alpha}}{\sqrt{\alpha}} D(c)$ . Thus, the Fourier transforms of the STs of two signals scaled between each other by

the factor  $\alpha$  are delayed by  $\ln \alpha$ .

In the following, we will consider signals with compact support, rescaled to  $[0,1]$ , i.e., the time variable is normalized dividing by  $T$  ( $T$  is not longer than the stimulation period). Hence, the integration in (5) is performed in the interval  $[0,1]$ , instead of  $[0,+\infty)$ . Being the scale operator self-adjoint [17], the set of eigenfunctions is complete, so that any square integrable function can be uniquely represented by the transform (5), and the signal can be obtained inverting the transform, i.e., evaluating the integral of the ST  $D(c)$  weighted by the eigenfunctions  $\frac{e^{jc \ln t}}{\sqrt{t}}$  of the scale operator.

The direct application of the ST to the signals  $x_1(t)$  and  $x_2(t)$  [Eq. (1)] for estimating the scale factor between them was proposed in [12]. In presence of signal truncation, the assumption of equal shape was not met, thus the STs of the two signals could have different magnitudes with a bias in the scale factor estimation. It was shown that this approach was less sensitive to signal truncation than the classic spectral analysis [12]. However, stimulation frequencies larger than 30-35 Hz determined too large biases in the scale factor estimation.

## B. Signal truncation

The STs of the signals  $x_1(t)$  and  $x_2(t)$  [Eq. (1)] are different in magnitude if  $T$  is shorter than the duration of  $x_2(t)$ . Thus, we should consider the signals  $\hat{x}_1(t, \alpha)$  and  $\hat{x}_2(t, \alpha)$  [Eqs. (3) and (4)], which, for  $\alpha = \alpha_0$ , are equal in shape.

Let's consider the ST of the signal  $\hat{x}_1(t, \alpha)$ :

$$D_1(c, \alpha) = \frac{1}{\sqrt{2\pi}} \int_0^1 \hat{x}_1(t, \alpha) \frac{e^{-jclnt}}{\sqrt{t}} dt = \frac{1}{\sqrt{2\pi}} \int_0^1 s(t) p_{[d, \alpha]}(t) \frac{e^{-jclnt}}{\sqrt{t}} dt = \frac{1}{\sqrt{2\pi}} \int_d^\alpha s(t) \frac{e^{-jclnt}}{\sqrt{t}} dt \quad (6)$$

where  $p_{[d, \alpha]}(t)$  is equal to 1 in the time interval  $[d, \alpha]$  and to 0 otherwise.

The ST of the signal  $\hat{x}_2(t, \alpha)$  can be written as:

$$\begin{aligned} D_2(c, \alpha) &= \frac{1}{\sqrt{2\pi}} \int_0^1 \hat{x}_2(t, \alpha) \frac{e^{-jclnt}}{\sqrt{t}} dt = \frac{1}{\sqrt{2\pi}} \int_0^1 s(\alpha_0 t) p_{[d/\alpha_0, 1]}(t) \frac{e^{-jclnt}}{\sqrt{t}} dt = \\ &= \frac{e^{jcln\alpha_0}}{\sqrt{\alpha_0}} \frac{1}{\sqrt{2\pi}} \int_{\frac{\alpha_0 d}{\alpha}}^{\alpha_0} s(y) \frac{e^{-jclny}}{\sqrt{y}} dy = \frac{e^{jcln\alpha_0}}{\sqrt{\alpha_0}} \tilde{D}(c, \alpha) \end{aligned} \quad (7)$$

with  $\tilde{D}(c, \alpha) = D_1(c, \alpha)$  for  $\alpha = \alpha_0$ , and  $y$  is the integration variable ( $y = \alpha_0 t$ ).

Both  $D_1(c, \alpha)$  and  $D_2(c, \alpha)$  depend on the selection of  $\alpha$ . If the scale factor  $\alpha$  is different from  $\alpha_0$ , the magnitude of  $D_1(c, \alpha)$  and  $D_2(c, \alpha)$  have different shapes. On the contrary, in case  $\alpha = \alpha_0$ , the magnitude of the two STs have the same shape (Fig. 3) and the Fourier transforms of  $D_1(c, \alpha)$  and  $D_2(c, \alpha)$  are delayed by the factor  $\ln \alpha_0$ . Thus, for  $\alpha = \alpha_0$ , the two functions  $D_1(c, \alpha)$  and  $\sqrt{\alpha} e^{-jcln\alpha} D_2(c, \alpha)$  are equal [Eq. (3)].

**Figure 3 about here**

Given the properties of  $D_1(c, \alpha)$  and  $D_2(c, \alpha)$ , we define the following quadratic error:

$$e^2(\alpha) = \int_0^1 \left| D_1(c, \alpha) - \sqrt{\alpha} e^{-jc \ln \alpha} D_2(c, \alpha) \right|^2 dc = \int_0^1 \left| D_1(c, \alpha) - \sqrt{\frac{\alpha}{\alpha_0}} e^{-jc \ln(\alpha/\alpha_0)} \tilde{D}(c, \alpha) \right|^2 dc \quad (8)$$

The function  $e^2(\alpha)$  is the mean square error between  $D_1(c, \alpha)$  and  $D_2(c, \alpha)$ , shifted in the frequency domain by the amount  $\ln \alpha$ . For each selection of the variable  $\alpha$ , the mean square error (8) defines the error between two STs derived from the two available signals. In the ideal case, the mean square error (8) is zero when  $\alpha = \alpha_0$ , regardless of the durations  $T$  and  $d$ . For experimental signals, the two STs are not exactly delayed in the frequency domain, due to noise and errors in the model assumed, thus the scale is estimated as the one corresponding to the minimum of the quadratic error (8).

Given the two recordings as in the model (1), we define the following estimator of the scale factor between the two signals:

$$\hat{\alpha}_0 = \arg \left[ \min_{\alpha} \left( \int_0^1 \int_d^{\alpha} x_1(t) \frac{e^{-jc \ln t}}{\sqrt{t}} dt - \sqrt{\alpha} e^{-jc \ln \alpha} \int_{d/\alpha}^1 x_2(t) \frac{e^{-jc \ln t}}{\sqrt{t}} dt \right)^2 dc \right] \quad (9)$$

which corresponds to the argument of the minimum of the mean square error (8). When the mean square error is zero, the scale factor  $\alpha_0$  is exactly estimated without any bias due to truncation since the two signals are truncated by exactly the same amount (with appropriate scaling). Due to the definitions of  $\hat{x}_1(t, \alpha)$  and  $\hat{x}_2(t, \alpha)$  [Eqs. (3) and (4)] (Figure 2), and the properties of the STs, the mean square error (8) is a complicate function of  $\alpha$ .

The minimum of  $e^2(\alpha)$  can be obtained by computing the STs of the signals  $\hat{x}_1(t, \alpha)$  and  $\hat{x}_2(t, \alpha)$  for a number of scale values  $\alpha$ . The scale value  $\alpha$  will also define the shift associated to the Fourier transform of  $D_2(c, \alpha)$ .

An exhaustive computation of the mean square error  $e^2(\alpha)$  for a number of  $\alpha$  values is time consuming and implies a limited resolution with which the scale is estimated. Indeed, a discrete step of  $\alpha$  should be selected. A better approach is to use an iterative method to find the zero of the first

derivative of  $e^2(\alpha)$ . For this purpose, the first and second derivatives of  $e^2(\alpha)$  should be analytically computed. Using the notation  $e^2(\alpha) = \int_0^1 |a-b|^2 dc$ , we can express the first and second derivative of the quadratic error (8) as:

$$\begin{aligned} \frac{d}{d\alpha} e^2(\alpha) &= 2 \operatorname{Re} \int_0^1 (\dot{a}a^* + \dot{b}b^* - \dot{a}b^* - \dot{b}a^*) dc \\ \frac{d^2}{d\alpha^2} e^2(\alpha) &= 2 \operatorname{Re} \int_0^1 (\ddot{a}a^* + |\dot{a}|^2 + \ddot{b}b^* + |\dot{b}|^2 - \ddot{a}b^* - \dot{a}\dot{b}^* - \ddot{b}a^* - \dot{b}\dot{a}^*) dc \end{aligned} \quad (10)$$

where the dot indicates differentiation with respect to  $\alpha$ , and the asterisk indicates the complex conjugate. The expressions of  $\dot{a}, \ddot{a}, \dot{b}, \ddot{b}$  can be obtained by analytical derivations (omitted):

$$\begin{aligned} \dot{a} &= \frac{\partial}{\partial \alpha} D_1 = x_1(\alpha) \frac{e^{-jc \ln \alpha}}{\sqrt{\alpha}} \\ \dot{b} &= \frac{\partial}{\partial \alpha} (\sqrt{\alpha} e^{-jc \ln \alpha} D_2) = \frac{0.5 - jc}{\sqrt{\alpha}} e^{-jc \ln \alpha} D_2 + \frac{\sqrt{d}}{\alpha} e^{-jc \ln \alpha} x_1\left(\frac{d}{\alpha}\right) \\ \ddot{a} &= \frac{\partial^2}{\partial \alpha^2} D_1 = \dot{x}_1(\alpha) \frac{e^{-jc \ln \alpha}}{\sqrt{\alpha}} - \frac{0.5 + jc}{\sqrt{\alpha}} x_1(\alpha) \frac{e^{-jc \ln \alpha}}{\alpha} \\ \ddot{b} &= \frac{\partial^2}{\partial \alpha^2} (\sqrt{\alpha} e^{-jc \ln \alpha} D_2) = -\frac{0.5 - jc}{\alpha \sqrt{\alpha}} e^{-jc \ln \alpha} D_2 - \frac{jc}{\alpha} \frac{0.5 - jc}{\sqrt{\alpha}} e^{-jc \ln \alpha} D_2 - \sqrt{d} \frac{jc}{\alpha^2} e^{-jc \ln d} x_1\left(\frac{d}{\alpha}\right) - \sqrt{d} \frac{d}{\alpha^3} e^{-jc \ln d} \dot{x}_1\left(\frac{d}{\alpha}\right) \end{aligned} \quad (11)$$

For a numerical implementation, all previous expressions must be sampled. For the sampling of the ST, the same approach proposed in [12] is adopted. Moreover, Eqs. (11) require the evaluation of the signals and their derivatives at specific time instants. These instants of time may be not exact multiple of the sampling period. However, we can substitute the signals and their derivatives in Eqs. (11) by the following equivalent expressions:

$$x_1(k) = \frac{1}{N} \sum_{w=0}^N X_1[w] e^{j2\pi w k / N}; \quad \dot{x}_1(k) = \frac{1}{N} \sum_{w=0}^N j2\pi w X_1[w] e^{j2\pi w k / N} \quad (12)$$

where  $N$  is the number of samples, and  $X_1[w]$  is the discrete Fourier transform of the time series  $x_1[n]$  [sampled version of  $x_1(t)$ ]. In this case,  $k$  can be any real number.

Given the two derivatives of the mean square error, as computed by Eqs. (11), an estimate of  $\alpha_0$  can be obtained by the following iteration:

$$\hat{\alpha}_{0,i+1} = \hat{\alpha}_{0,i} - \frac{\left. \frac{de^2(\alpha)}{d\alpha} \right|_{\hat{\alpha}_{0,i}}}{\left. \frac{d^2e^2(\alpha)}{d\alpha^2} \right|_{\hat{\alpha}_{0,i}}} \quad i = 0,1,\dots \quad (13)$$

starting from a coarse estimate  $\hat{\alpha}_{0,0}$ . Since the process of M-wave widening evolves progressively in time, a coarse estimate  $\hat{\alpha}_{0,0}$  can be the scale factor between the previous M-wave and the reference. Fig. 4 shows a schematic diagram of the method proposed.

**Figure 4 about here**

### C. Simulated signals

The method described above was tested on both simulated and experimental signals. The simulated signals were generated by a structure-based model [18]. For testing the method and comparing it with previous approaches, a single fiber action potential has been simulated to describe an M-wave. This strong simplification of the M-wave is not a concern for the purpose of the comparison between methods of estimation of signal widening. A scale factor corresponding to 0.5, 0.6, 0.7, 0.8, and 0.9 was applied to the simulated action potential, according to an M-wave widening model of Eq. (1). Additive white Gaussian noise was added to the signals with signal-to-noise ratio 5 dB, 10 dB, and 20 dB. For each signal-to-noise ratio, 100 signal realizations were generated. The time interval of signal observation was varied in order to change the degree of signal truncation (see Results).

The approach proposed for scale factor estimation was applied to the simulated signals. For comparison with previous techniques, the scale factor was also estimated a) by directly applying the ST to the two signals without considering a signal truncation [12], and b) from the mean power spectral frequency (MNF). The MNF was normalized with respect to the value assumed for the

signal with scale factor 1 (reference signal in the case of scale factor estimation). Median frequency resulted in similar results (not shown) as MNF.

## **EXPERIMENTAL PROCEDURE**

### **A. Experimental protocol**

Eleven male healthy subjects (age, mean  $\pm$  SD,  $26.8 \pm 2.7$  years, stature,  $178 \pm 6.8$  cm, weight,  $73.1 \pm 8.4$  kg) participated to the measurements. The study was approved by the Local Ethics Committee of the Health Department of Region Piemonte, Italy, and written informed consent was obtained from all participants prior to inclusion.

Surface EMG signals were recorded from the right (dominant) biceps brachii muscle. A brace was used to fix the subjects' arm for an isometric contraction. The forearm was placed at  $120^\circ$  flexion (being  $180^\circ$  the full extension of the forearm). The subject sat on a chair, with the arm  $90^\circ$  flexed ( $0^\circ$  being the angle corresponding to the arm along the body). A  $40 \text{ cm}^2$  electrode was placed on the triceps muscle, to close the current path during stimulation. The motor points of the biceps brachii were then identified with electrical stimulation at 2 Hz, using a pen electrode of  $1 \text{ cm}^2$ . The point corresponding to the maximal mechanical response elicited by the minimal current was defined as the motor point for the stimulation. An adhesive electrode of  $1 \text{ cm}^2$  surface was fixed on the selected point.

Surface EMG signals were detected by a linear adhesive array (LISiN-SPES Medica, Torino, Italy) of 8 electrodes with 5 mm inter-electrode distance in single differential configuration. The EMG signals were amplified (LISiN-PRIMA Biomedical & Sport, Treviso, Italy), filtered (3-dB bandwidth 10-500 Hz), sampled at 2048 Hz, and digitized by a 12-bit A/D converter. To ensure synchronous sampling, the seven differential channel amplifier incorporated sample and hold circuits. The acquisition board was triggered by the stimuli from the stimulator.

Stimulations at 2 Hz with progressively increasing current intensity were delivered to determine the supra-maximal stimulation current, which corresponded to the current beyond which the M-wave

did not further significantly increase in amplitude [1]. Stimulations at 20, 40, and 60 Hz, sustained for 10 s each, at the supra-maximal current were then applied to the subjects. After 5-min rest from the determination of the supra-maximal current, the first elicited contraction at 20 Hz was performed. Five-minute rest was allowed after this contraction which was followed by the contractions at stimulation frequencies 40 Hz and 60 Hz, separated by 10-min rest.

## **B. Signal analysis**

Of the seven bipolar signals detected during the experimental session, only the central one was considered for further analysis in this study. The experimental signals were divided into epochs of 1 s. The M-waves detected in one epoch were averaged [1]. The M-wave in the first epoch was considered as the reference signal (scale factor 1). The scale factor was computed considering the first epoch as reference and each of the other epochs, obtaining a total of nine scale factor values. Mean frequency was computed from the 10 epochs and its values were normalized with respect to that obtained in the first epoch. In ideal conditions of scale changes without truncation, the normalized MNF should coincide with the scale factor.

The new method was applied to both simulated and experimental signals setting  $d = 0$ , thus no samples were excluded at the beginning of the signals. This allowed proper comparison with the other methods.

## **C. Statistical analysis**

Scale factors and normalized MNF estimated from the experimental signals were analyzed using three-way repeated measures analysis of variance (ANOVA), followed by post-hoc Student-Newman-Keuls (SNK) pair-wise comparisons, when required [19]. The factors in the ANOVA were the method used for estimating the scale factor (new method, direct application of the ST, and normalized MNF), stimulation frequency, and epoch. Statistical significance was set to  $P < 0.05$ . Data are presented as mean  $\pm$  standard deviation (SD) and mean  $\pm$  standard error (SE), as indicated.

## **RESULTS**

### **A. Simulation**

Fig. 5 reports an example of estimation of scale factor by the different methods tested when increasing signal widening for a finite time interval of observation for simulated EMG signals. The method proposed was less affected by signal truncation than the direct application of the ST. The results indicated that MNF is a poor estimator of scale factor when truncation occurs. Fig. 6 reports the results on the complete set of simulations. The interval of observation was in this case limited to 22 samples (see Fig. 5c). The signal-to-noise ratio had a small effect on the mean value of the scale factor estimates while it had a larger impact on normalized MNF.

**Figures 5 and 6 about here**

### **B. Experimental signals**

Fig. 7 reports the scale factor estimates at the three stimulation frequencies. Scale factor tended to decrease over time, indicating the widening of the M-wave due to reduction in average muscle fiber conduction velocity [1]. Thus, the scale factor can be considered a fatigue index. When normalized MNF was used to estimate the scale factor, M-wave truncation hindered the decreasing trend at high stimulation frequencies (40 and 60 Hz) while the new method clearly revealed M-wave widening. It has to be noted that at 60 Hz stimulation frequency, M-wave scale factor decreased to 0.4 at the end of the contraction with respect to the average M-wave in the first epoch (Fig. 7). Thus, M-wave duration increased more than twice in these conditions.

A three-way ANOVA of the estimated scale factor was significant for the method, stimulation frequency, and epoch and for the interaction among these factors ( $F > 8.1$ ,  $P < 0.01$ ; interaction among factors:  $F = 3.65$ ,  $P < 0.0001$ ). When analysing the effect of stimulation frequency and epoch with SNK post-hoc pair-wise comparisons, the new method led to scale factor estimates different for all stimulation frequencies ( $P < 0.05$ ; mean  $\pm$  SD,  $0.97 \pm 0.04$ , 20 Hz,  $0.82 \pm 0.17$ , 40

Hz, and  $0.62 \pm 0.30$ , 60 Hz). Moreover, the scale factor estimated with the new method was significantly different among all epochs ( $P < 0.05$ ), except between epochs 3, 4, 5, 6 and between 7, 8, 9. The scale factor estimated applying the ST directly to the signals was different only between 20 Hz and 60 Hz ( $P < 0.05$ ;  $0.97 \pm 0.04$ , 20 Hz,  $0.91 \pm 0.08$ , 40 Hz, and  $0.84 \pm 0.23$ , 60 Hz), while normalized MNF (mean  $\pm$  SD,  $0.97 \pm 0.04$ , 20 Hz,  $0.95 \pm 0.20$ , 40 Hz, and  $1.04 \pm 0.18$ , 60 Hz) did not depend on the stimulation frequency. The first five epochs resulted in different scale factors, when directly applying the ST to the signals, compared with the last four epochs ( $P < 0.05$ ), while normalized MNF did not change with the epoch.

### **Figure 7 about here**

When comparing the three methods by post-hoc pair-wise comparisons, the new method led to significantly lower scale factor estimates than the other two methods for the last two epochs at 40 Hz stimulation frequency ( $P < 0.05$ ). At 60 Hz, the method proposed resulted in significantly lower estimates than the other two methods for the first 4 and the last 2 epochs ( $P < 0.05$ ); for the other epochs the method proposed and the ST directly applied to the signals resulted different from normalized MNF ( $P < 0.05$ ).

## **DISCUSSION AND CONCLUSION**

A novel method for assessing the scale factor between two M-waves has been proposed. The method provides an alternative parameter which can be used as a fatigue index. The parameter is derived in the time domain and is almost insensitive to a possible truncation of the M-wave, thus it can be applied to investigate changes in M-wave duration during electrically elicited contractions at high stimulation frequencies. This may provide a quantitative method to design and compare rehabilitation and training protocols [13][16].

The method considers the average M-wave from the first signal epoch as reference and computes the scale factor between subsequent average M-waves and the reference. As for previous methods, this estimator of scale factor is based on some approximations when it was applied to the M-wave. It is assumed that the two M-waves have the same shape [model (1)] and are scaled between each other. This is a simplified model of the complex changes which occur in the M-wave during repeated stimulation. The M-wave is the summation of action potentials of different motor units, which have a distribution of conduction velocities [20]. The rate of change of the velocities of propagation during sustained contraction depends on the motor unit type, thus the distribution of conduction velocity may change shape. Moreover, there can be phenomena of loss of sarcolemma excitability with sustained activation [21], with the consequent change of the active MU pool and shape of the compound potential. Thus, the model assuming a pure scaling of the M-wave with time is a simplification of the practical situation. However, it constitutes a good approximation and allows the reduction of the phenomenon to a single parameter, which is useful for the clinical application of the method.

The experimental results reported in this study show for the first time quantitative myoelectric fatigue assessment at stimulation rates as high as 60 Hz, for contractions sustained until significant fatigue was present. This opens interesting perspectives in the analysis of muscle fiber membrane properties during high activation frequency.

The method is fast and has no limits in resolution. Moreover, it is relatively little sensitive to additive noise (Fig. 6), thus it can be applied in practical cases. An additional advantage of the method is that it can work on any portion of the M-wave. It is possible to truncate the M-wave at the beginning of its temporal support in order to avoid the stimulation artefact in the computation of the scale factor. This truncation does not generate bias in the method since the two signals from which the scale factor is computed will always have exactly the same shape, in ideal conditions. Thus, the influence of the artefact on the scale estimation is nullified by the proposed approach. This is particularly important when the artefact and the M-wave are significantly overlapped [22].

In these conditions, the introduction of a traditional blanking [23] will introduce high frequency components in the M-wave and bias the characteristic spectral frequencies. It has to be noted that the artefact represents a signal portion which does not scale as the M-wave, thus its presence may affect the rate of change of the scale factor.

In addition to avoiding the stimulation artefact, removing the first portion of the M-wave may improve the scale factor estimation since the previous M-wave partially overlaps at the beginning of the signal. Since the method proposed can work on any signal portion, the interval in which the scale is estimated can be selected in order to have a minimal effect due to the tail of the preceding M-wave.

In conclusion, we proposed a novel method for estimating the scale factor between M-waves detected during sustained tetanic stimulation. The method provides a new variable for quantifying the M-wave widening during sustained activation. The estimated scale factor was almost insensitive to significant M-wave truncations, as assessed by both experimental and model results.

## **ACKNOWLEDGEMENTS**

This work was partially supported by contract C15097/01/NL/SH of the European Space Agency (ESA) on Microgravity effects on skeletal muscles investigated by surface EMG and mechanomyogram (MESM), by the Italian Space Agency (contract number ASI I/R/137/01), and PRIMA Biomedical & Sport, Treviso, Italy.

## REFERENCES

- [1] R. Merletti, M. Knaflitz, C.J. DeLuca, "Electrically evoked myoelectric signals," *Crit. Rev. Biomed. Eng.*, vol. 19, pp. 293-340, 1992
- [2] B. Bigland-Ritchie, J.J. Woods, "Changes in muscle contractile properties and neural control during human muscular fatigue," *Muscle Nerve*, vol. 7, pp. 691-699, 1984
- [3] R. Merletti, C.J. De Luca, D. Sathyan, "Electrically evoked myoelectric signals in back muscles: effect of side dominance," *Journ. Appl. Physiol.*, vol. 77, pp. 2104-2114, 1994
- [4] R. Merletti, A. Fiorito, L. R. LoConte, C. Cisari, "Repeatability of electrically evoked EMG signals in the human vastus medialis muscle," *Muscle Nerve*, vol. 21, pp. 184-193, 1998
- [5] C. Chisari, C. D'Alessandro, M.L. Manca, B. Rossi, "Sarcolemmal excitability in myotonic dystrophy: assessment through surface EMG," *Muscle Nerve*, vol. 21, pp. 543-546, 1998
- [6] G.K. Fitzgerald, S.R. Piva, J.J. Irrgang, "A modified neuromuscular electrical stimulation protocol for quadriceps strength training following anterior cruciate ligament reconstruction," *Journ. Orthop. Sports Phys. Ther.*, vol. 33, pp. 492-501, 2003
- [7] N.A. Dimitrova, G.V. Dimitrov, "Interpretation of EMG changes with fatigue: facts, pitfalls, and fallacies," *Journ. Electromyogr. Kinesiol.*, vol. 13, pp. 13-36, 2003
- [8] R. Merletti, L.R. Lo Conte, "Advances in processing of surface myoelectric signals: Part 1," *Med. Biol. Eng. Comput.*, vol. 33, pp. 362-72, 1995
- [9] L.R. Lo Conte, R. Merletti, G.V. Sandri, "Hermite expansions of compact support waveforms: applications to myoelectric signals," *IEEE Trans. Biomed. Eng.*, vol. 41, pp. 1147-59, 1994
- [10] L.R. Lo Conte, R. Merletti, "Advances in processing of surface myoelectric signals: Part 2," *Med. Biol. Eng. Comput.*, vol. 33, pp. 373-84, 1995
- [11] G. Olmo, F. Laterza and L. Lo Presti, "Matched wavelet approach in stretching analysis of electrically evoked surface EMG," *Signal Processing*, vol. 80, pp. 671-684, 2000
- [12] W. Muhammad, O. Meste, H. Rix, D. Farina, "A pseudojoint estimation of time delay and scale factor for M-wave analysis," *IEEE Trans. Biomed. Eng.*, vol. 50, pp. 459-68, 2003

- [13] D.M. Selkowitz, "High frequency electrical stimulation in muscle strengthening. A review and discussion", *Am. J. Sports Med.*, vol. 17, pp. 103-11, 1989.
- [14] V.A. Convertino, H. Sandler, "Exercise countermeasures for spaceflight," *Acta Astronaut.*, vol. 35, pp. 253-70, 1995
- [15] M.R. Duvoisin, V.A. Convertino, P. Buchanan, P.D. Gollnick, G.A. Dudley, "Characteristics and preliminary observations of the influence of electromyostimulation on the size and function of human skeletal muscle during 30 days of simulated microgravity," *Aviat. Space Environ. Med.*, vol. 60, pp. 671-8, 1989
- [16] N. Mourselas, M.H. Granat, "Muscle fatigue from intermittent stimulation with low and high frequency electrical pulses", *Arch. Phys. Med. Rehabil.*, vol. 80, pp. 48-53, 1999.
- [17] L. Cohen, "The scale representation," *IEEE Trans. Signal Processing*, vol. 41, pp. 3275-3292, 1993
- [18] D. Farina, L. Mesin, S. Martina, R. Merletti, "A surface EMG generation model with multi-layer cylindrical description of the volume conductor," *IEEE Trans. Biomed. Eng.*, vol. 51, pp. 415-26, 2004.
- [19] D. C. Montgomery (2001). *Design and Analysis of Experiments*. 5th Edition. John Wiley & Sons, New York, 2001
- [20] W. Troni, R. Cantello, I. Rainero, "Conduction velocity along human muscle fibers in situ," *Neurology*, vol. 33, pp. 1453-9, 1983
- [21] C. Chisari, C. Simonella, B. Rossi, "A surface EMG analysis of sarcolemma excitability alteration and myofibre degeneration in Steinert disease", *Clin. Neurophysiol.*, vol. 112, pp. 1925-30, 2001
- [22] F. Mandrile, D. Farina, M. Pozzo, R. Merletti, "Stimulation artifact in surface EMG signal: effect of the stimulation waveform, detection system, and current amplitude using hybrid stimulation technique," *IEEE Trans. Neural Syst. Rehab. Eng.*, vol. 11, pp. 407-15, 2003

[23] M. Knaflitz, R. Merletti, "Suppression of simulation artifacts from myoelectric-evoked potential recordings", *IEEE Trans. Biomed. Eng.*, vol. 35, pp. 758-63, 1988.

## FIGURE CAPTIONS

**Fig. 1** a) M-waves detected during muscle stimulation at 40 Hz for 10 s. The first (reference) and last detected M-waves are indicated by thick lines and are also shown in (b), (c). The last M-wave is truncated by a greater amount than the reference one due to the widening. The thick line in (b) indicates the portion of the reference signal equal in shape to the truncated last M-wave. This portion is scaled by the estimated scale factor and shown in (d).

**Fig. 2** The signals  $\hat{x}_1(t, \alpha_0)$  and  $\hat{x}_2(t, \alpha_0)$  derived from a period  $T$  (also equal to the observation interval) of a sinusoidal function  $x_1(t)$  and its scaled version  $x_2(t)$ . The scale factor  $\alpha_0$  is 0.75. Since the observation interval  $T$  is shorter than the temporal support of  $x_2(t)$ , the signals  $x_1(t)$  and  $x_2(t)$  have different shapes (a). The signals  $\hat{x}_1(t, \alpha_0)$  and  $\hat{x}_2(t, \alpha_0)$  are obtained from the truncation (at the beginning and end of the observation interval) of the original signals, so that the resultant signals are exactly equal in shape and scaled between each other (see text for details) (b and c). Since  $\alpha_0$  is unknown, only the signals  $\hat{x}_1(t, \alpha)$  and  $\hat{x}_2(t, \alpha)$ , with  $\alpha$  unknown, are available in practice. These signals have the same shape only for  $\alpha = \alpha_0$ , as shown in this example.

**Fig. 3** Two simulated signals scaled between each other and observed for a time interval shorter than the duration of the second signal. a) Reference signal with four possible truncations. b) The second signal considered, which is the scaled version of the reference signal. c) The ST of the reference signal for the different truncations. The truncation indicated by 3 corresponds to having the same shape of the second signal. d) The ST of the signal in (b).

**Fig. 4** Schematic representation of the proposed method for estimation of the scale factor. The minimum of the mean square error is determined by the Newton iterative procedure (see text or details). At each step, the original signals are truncated to obtain the signals  $\hat{x}_1(t, \alpha)$  and  $\hat{x}_2(t, \alpha)$  (with  $\alpha$  the estimated scale factor at the previous step). The ratio between the first and second derivative of the mean square error between the STs of the two truncated signals is used to update the estimate of the scale factor [Eq. (13)].

**Fig. 5** a) Simulated noise-free signals of equal shape and scaled between each other. The scale factor is estimated by the proposed approach, by direct application of the STs, and by normalized MNF, from 30 (b), 22 (c), and 18 (d) samples. The scale factor of the 21 signals is estimated with respect to the first signal taken as reference and changes from 1 to 0.5 in the 21 steps.

**Fig. 6** Estimation of scale factor (mean  $\pm$  SD) as a function of the ideal scale factor from the signals shown in Fig. 5 with 22 samples considered. For each signal to noise ratio, 100 realizations have been generated. MNF values have been normalized with respect to the value assumed for a scale factor equal to 1 (not shown).

**Fig. 7** Scale factor estimation (mean  $\pm$  SE, N = 11 subjects) during the stimulated contractions at the three stimulation frequencies for the three methods compared. The value of  $d$  (Fig. 4) has been fixed to zero in all cases.

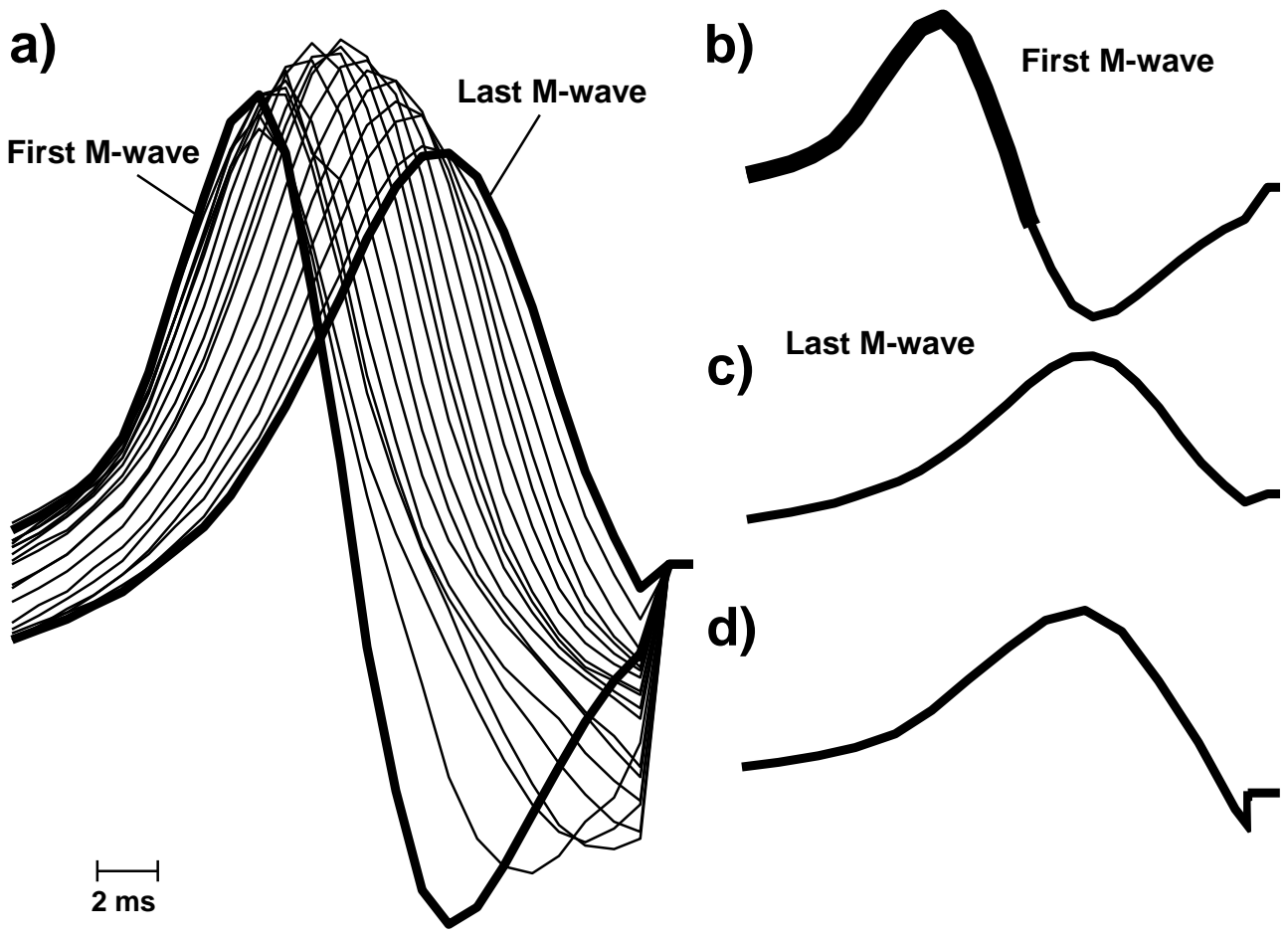

Figure 1

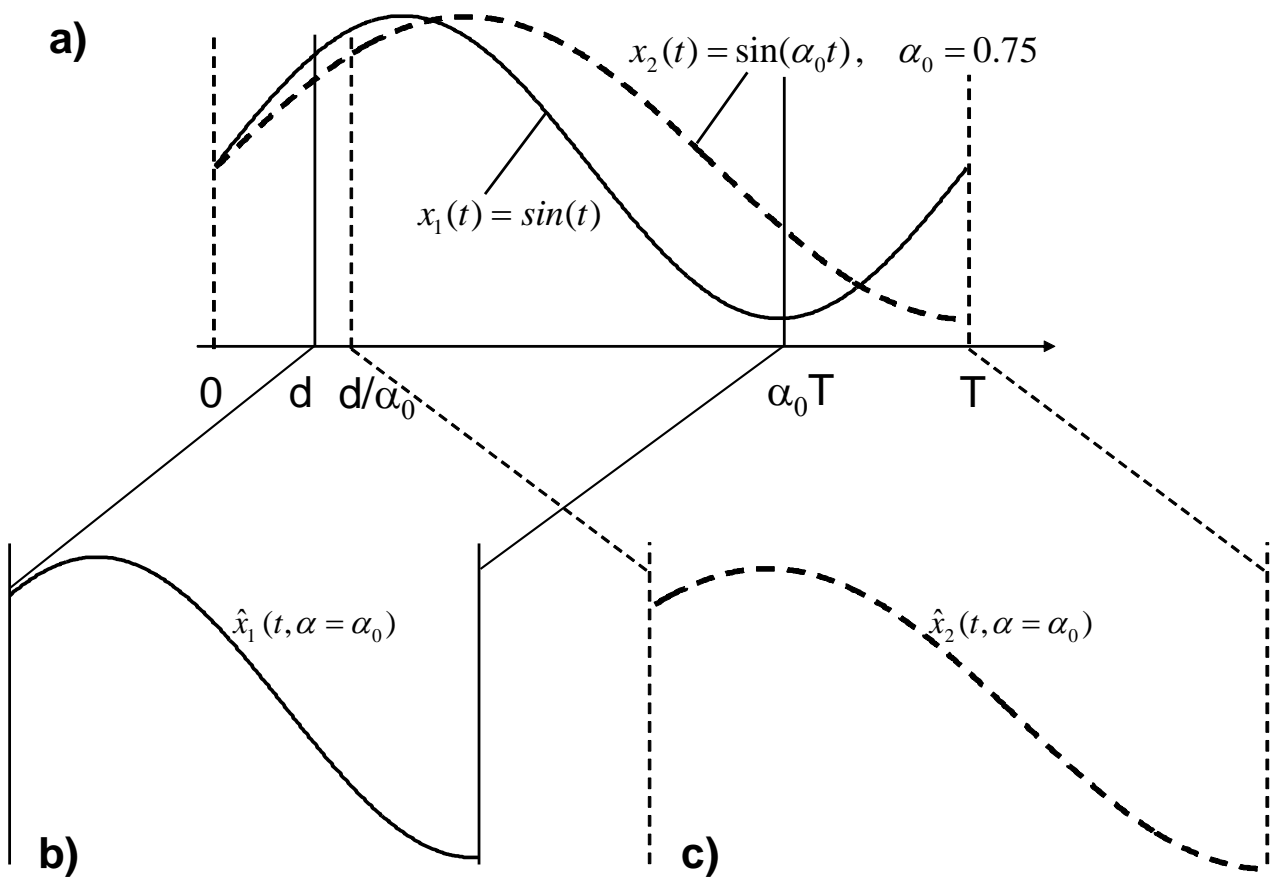

Figure 2

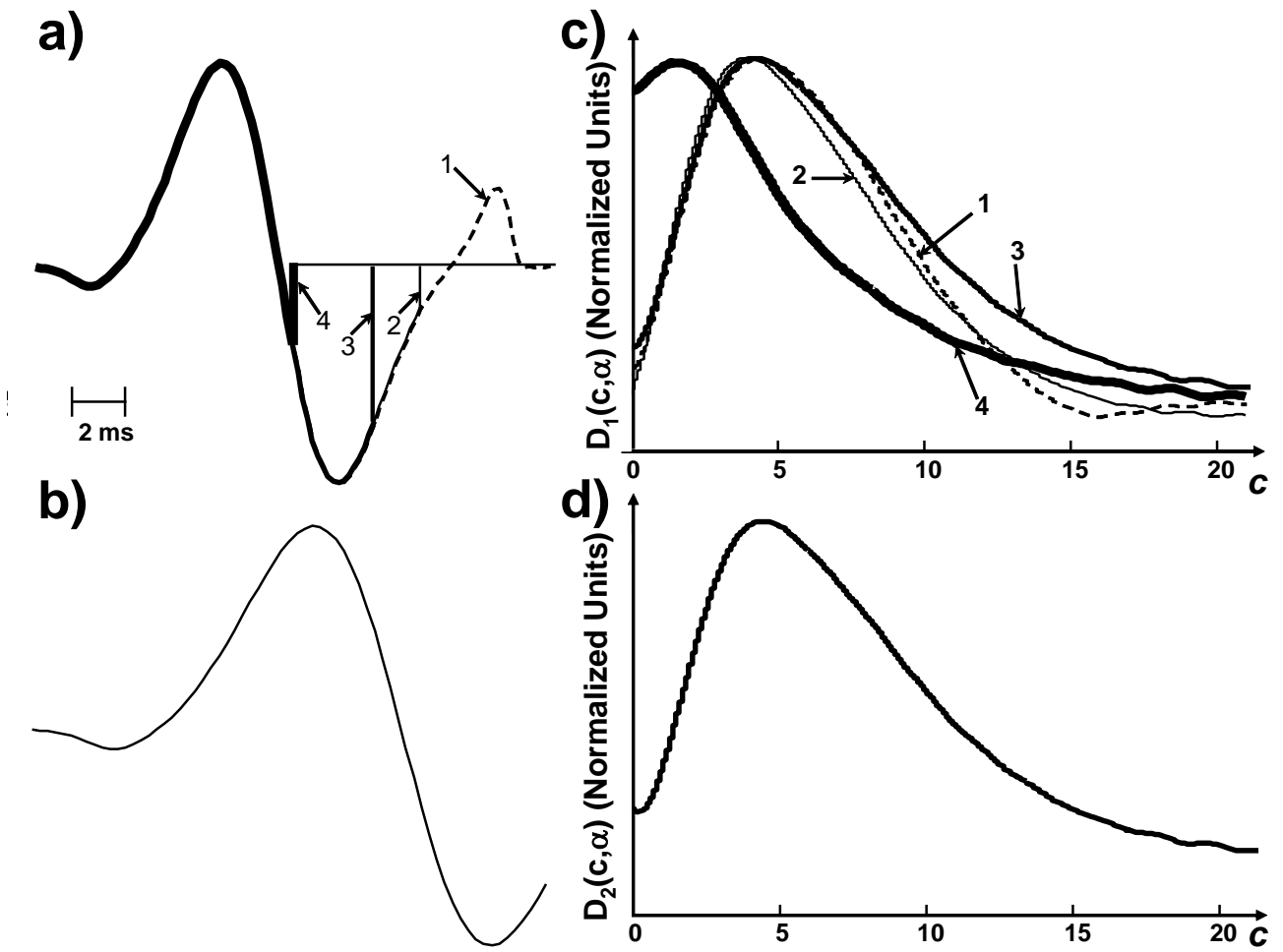

Figure 3

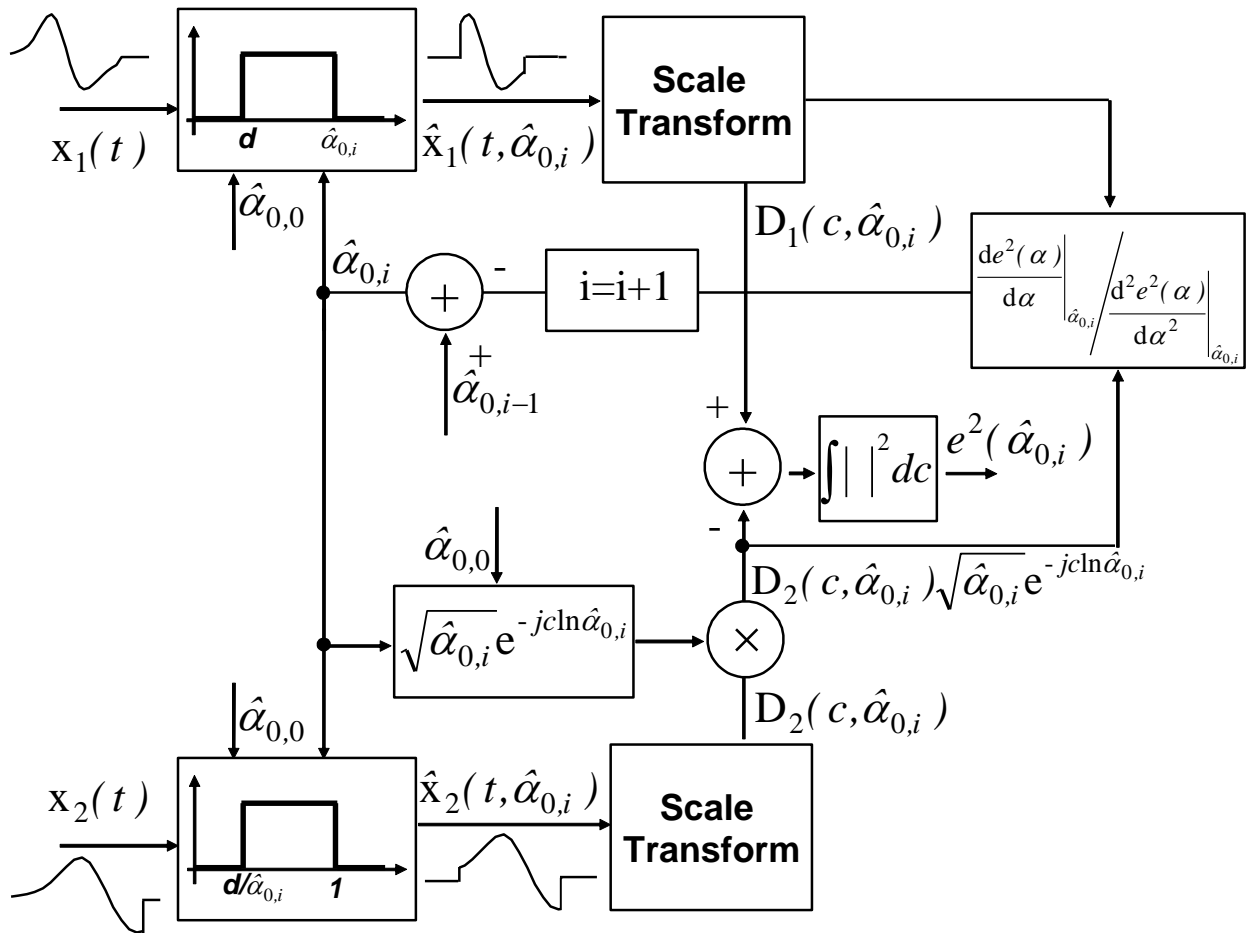

Figure 4

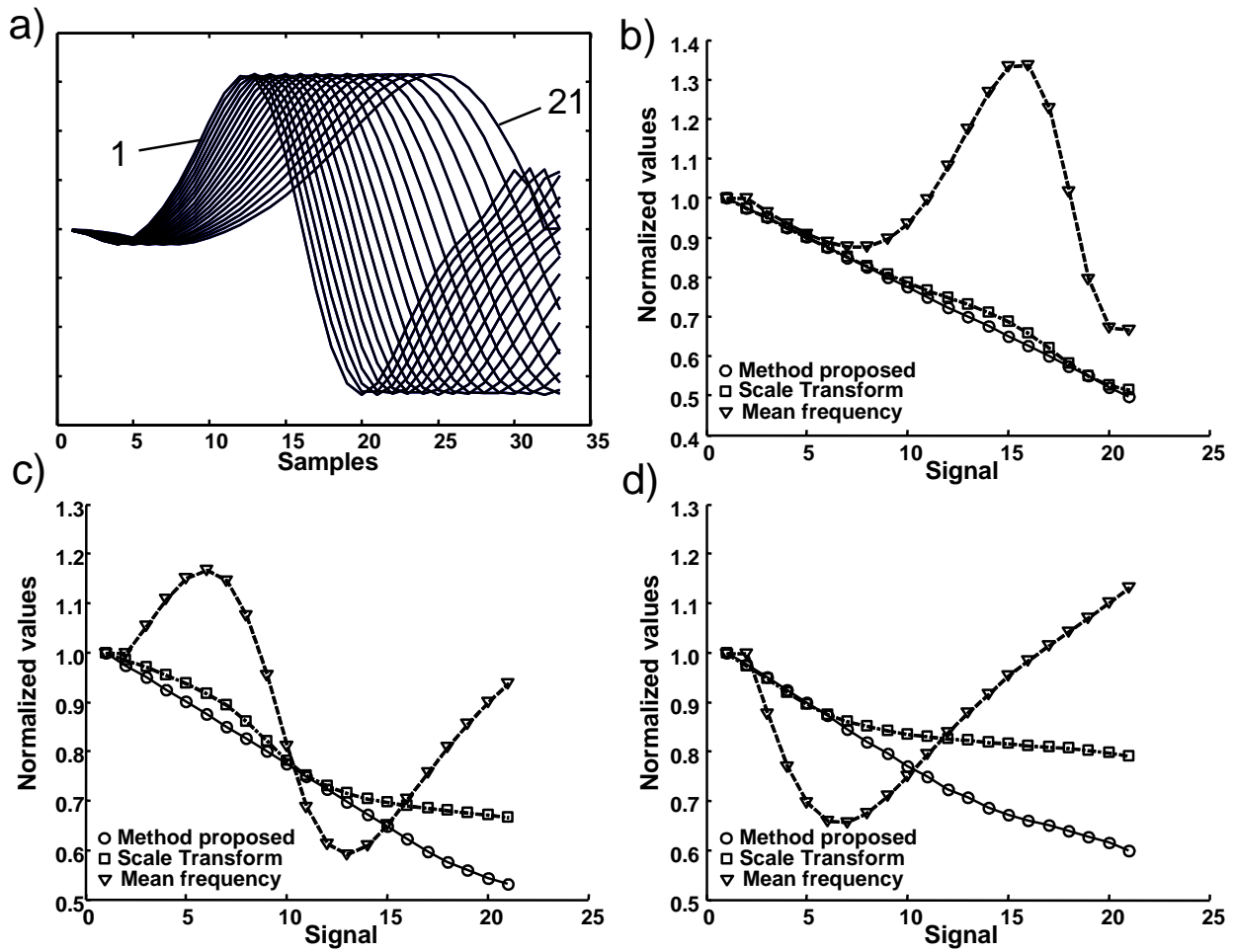

Figure 5

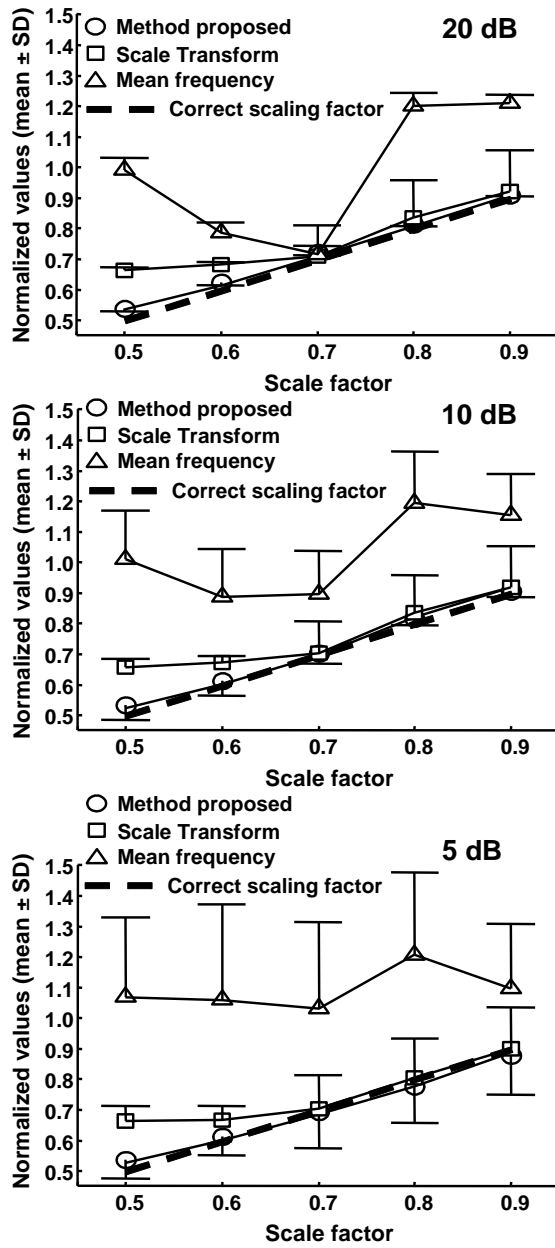

Figure 6

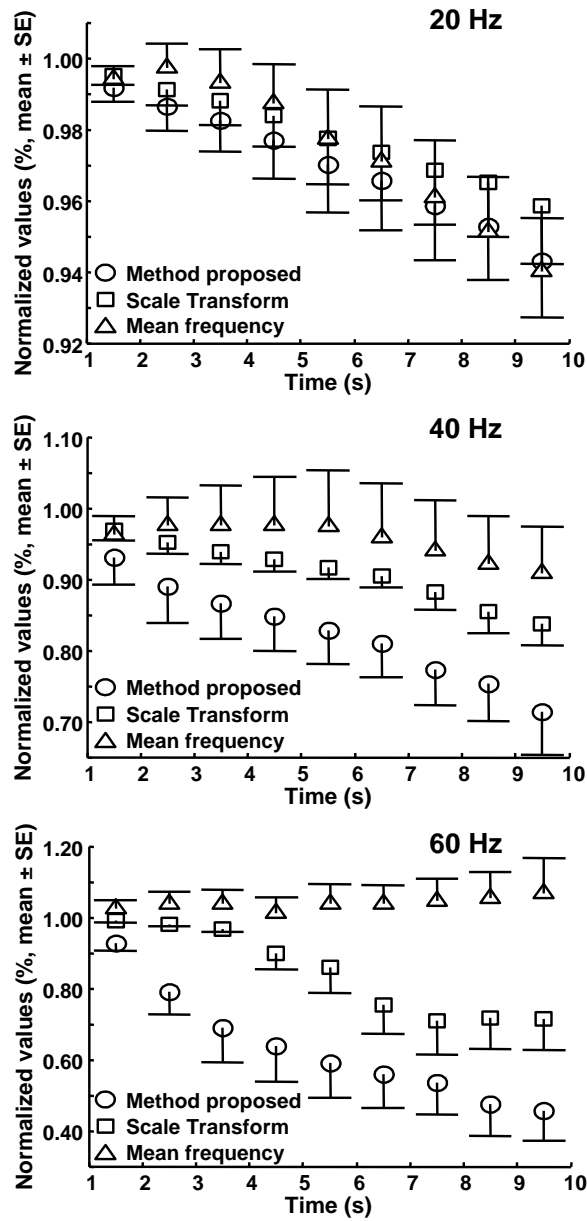

Figure 7